

P-Channel Enhancement MOSFET

■ Features

- $V_{DS} (V) = -30V$
- $I_D = -4.1 A$
- $R_{DS(ON)} < 52m \Omega$ ($V_{GS} = -10V$)
- $R_{DS(ON)} < 87m \Omega$ ($V_{GS} = -4.5V$)

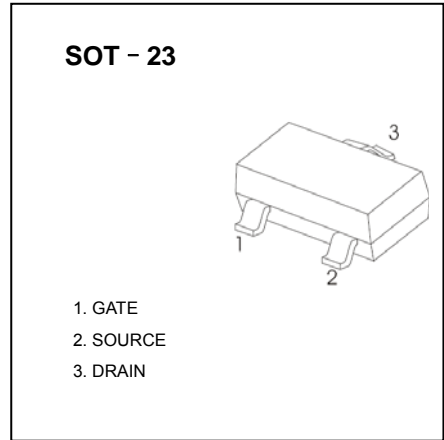
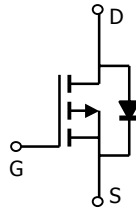

■ Absolute Maximum Ratings $T_a = 25^\circ C$

| Parameter | Symbol | Rating | Unit |
|--|------------|--------------------|--------------|
| Drain-Source Voltage | V_{DS} | -30 | V |
| Gate-Source Voltage | V_{GS} | ± 20 | |
| Continuous Drain Current $T_a = 25^\circ C$ | I_D | -4.1 | A |
| | | $T_a = 70^\circ C$ | |
| Pulsed Drain Current | I_{DM} | -20 | |
| Power Dissipation $T_a = 25^\circ C$ | P_D | 1.4 | W |
| | | $T_a = 70^\circ C$ | |
| Thermal Resistance.Junction- to-Ambient $t \leq 10s$ Steady State | R_{thJA} | 90 | $^\circ C/W$ |
| | | 125 | |
| Thermal Resistance.Junction- to-Lead | R_{thJL} | 60 | |
| Junction Temperature | T_J | 150 | $^\circ C$ |
| Storage Temperature Range | T_{stg} | -55 to 150 | |

■ Electrical Characteristics Ta = 25°C

| Parameter | Symbol | Test Conditions | Min | Typ | Max | Unit |
|---------------------------------------|---------------------|--|--|-------|------|------|
| Drain-Source Breakdown Voltage | V _{DSS} | I _D =-250 μ A, V _{GS} =0V | -30 | | | V |
| Zero Gate Voltage Drain Current | I _{DSS} | V _{DS} =-24V, V _{GS} =0V | | | -1 | μ A |
| | | V _{DS} =-24V, V _{GS} =0V, T _J =55°C | | | -5 | |
| Gate-Body leakage current | I _{GSS} | V _{DS} =0V, V _{GS} =±20V | | | ±100 | nA |
| Gate Threshold Voltage | V _{GS(th)} | V _{DS} =V _{GS} I _D =-250 μ A | -1 | -1.8 | -3 | V |
| Static Drain-Source On-Resistance | R _{DS(on)} | V _{GS} =-10V, I _D =-4.1A | | 40.5 | 52 | mΩ |
| | | V _{GS} =-10V, I _D =-4.A T _J =125°C | | 57 | 73 | |
| | | V _{GS} =-4.5V, I _D =-3A | | 64 | 87 | |
| On state drain current | I _{D(ON)} | V _{GS} =-4.5V, V _{DS} =-5V | -10 | | | A |
| Forward Transconductance | g _{FS} | V _{DS} =-5V, I _D =-4A | 5.5 | 8.2 | | S |
| Input Capacitance | C _{iss} | V _{GS} =0V, V _{DS} =-15V, f=1MHz | | 700 | | pF |
| Output Capacitance | C _{oss} | | | 120 | | |
| Reverse Transfer Capacitance | C _{rss} | | | 75 | | |
| Gate resistance | R _g | | V _{GS} =0V, V _{DS} =0V, f=1MHz | | 10 | |
| Total Gate Charge | Q _g | V _{GS} =-4.5V, V _{DS} =-15V, I _D =-4A | | 14.3 | | nC |
| Gate Source Charge | Q _{gs} | | | 7 | | |
| Gate Drain Charge | Q _{gd} | | | 3.1 | | |
| Turn-On DelayTime | t _{d(on)} | V _{GS} =-10V, V _{DS} =-15V, R _L =3.6Ω, R _{GEN} =3Ω | | 8.6 | | ns |
| Turn-On Rise Time | t _r | | | 5 | | |
| Turn-Off DelayTime | t _{d(off)} | | | 28.2 | | |
| Turn-Off Fall Time | t _f | | | 13.5 | | |
| Body Diode Reverse Recovery Time | t _{rr} | I _F =-4A, di/dt=100A/μ s | | 27 | | nC |
| Body Diode Reverse Recovery Charge | Q _{rr} | | | 15 | | |
| Maximum Body-Diode Continuous Current | I _S | | | | -2.2 | A |
| Diode Forward Voltage | V _{SD} | I _S =-1A, V _{GS} =0V | | -0.77 | -1 | V |

■ Typical Characteristics

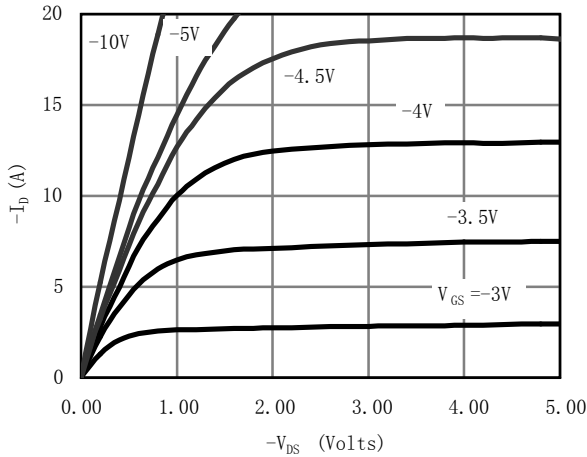

Figure 1: On-Region Characteristics

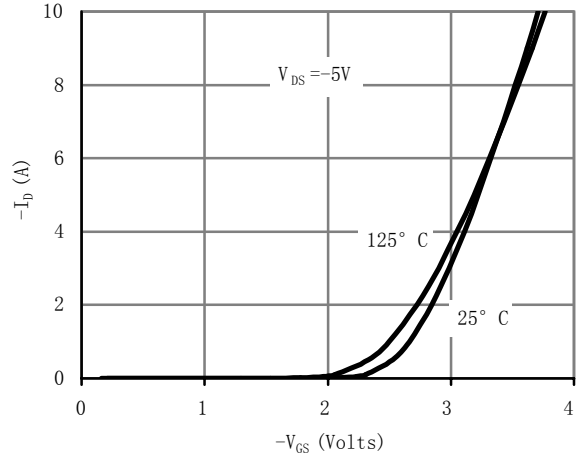

Figure 2: Transfer Characteristics

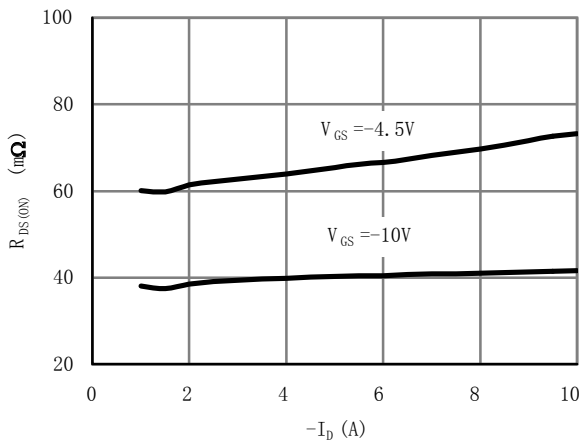

Figure 3: On-Resistance vs. Drain Current and Gate Voltage

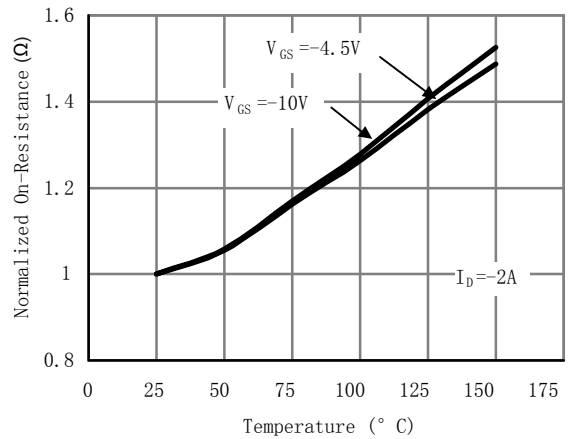

Figure 4: On-Resistance vs. Junction Temperature

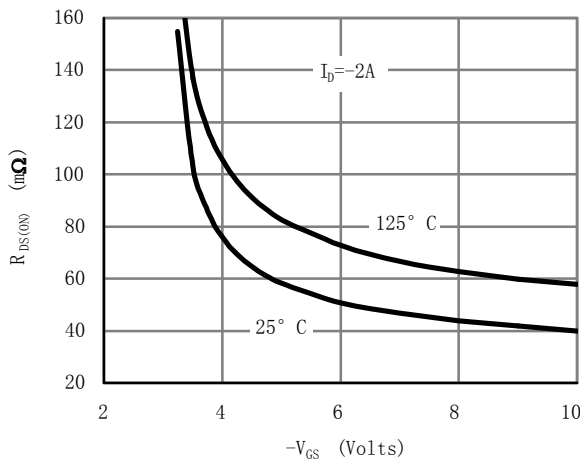

Figure 5: On-Resistance vs. Gate-Source Voltage

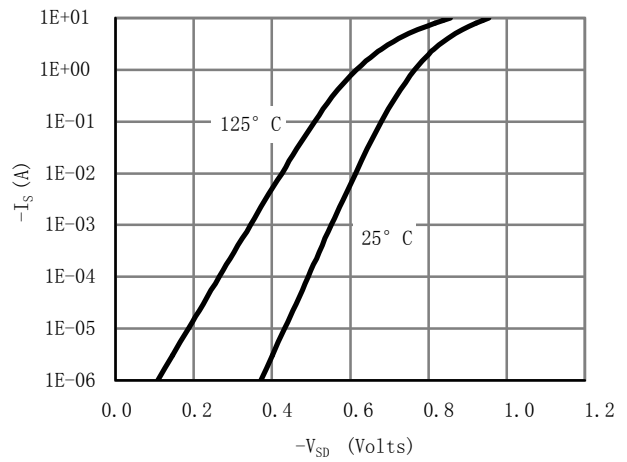

Figure 6: Body-Diode Characteristics

■ Typical Characteristics

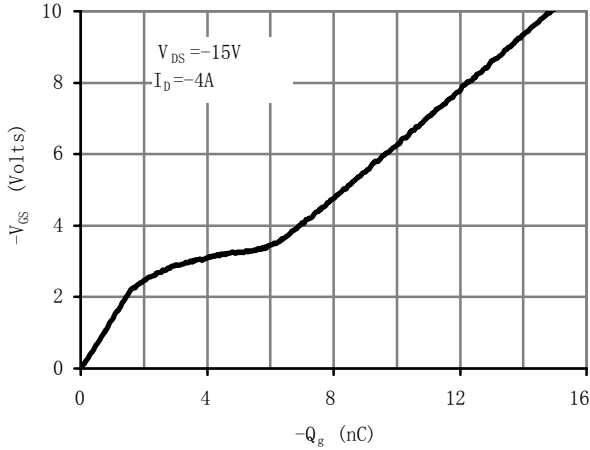

Figure 7: Gate-Charge Characteristics

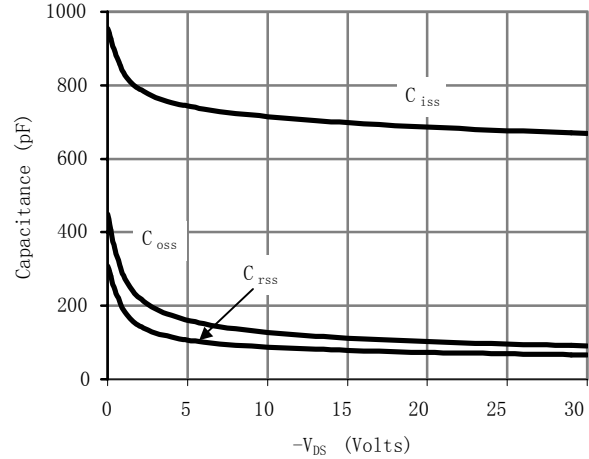

Figure 8: Capacitance Characteristics

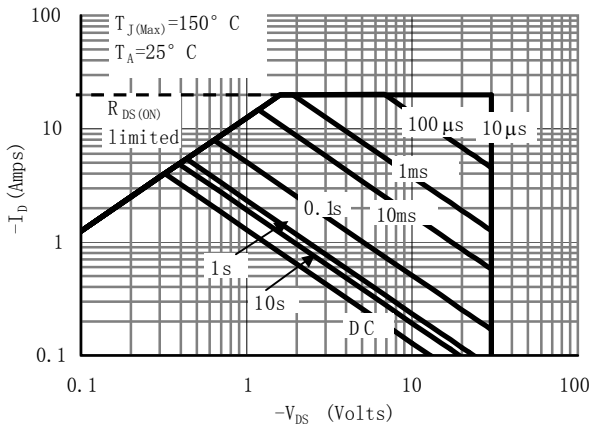

Figure 9: Maximum Forward Biased Safe Operating Area (Note E)

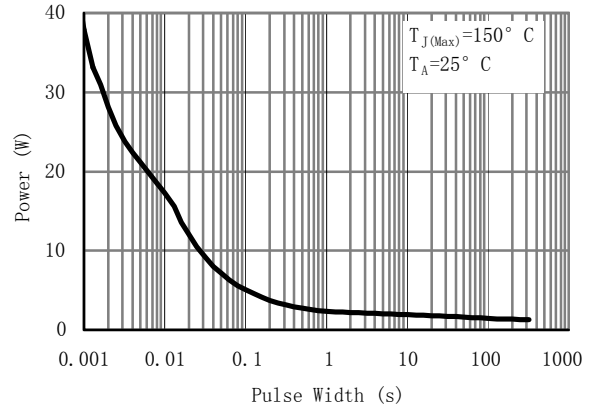

Figure 10: Single Pulse Power Rating Junction-to-Ambient (Note E)

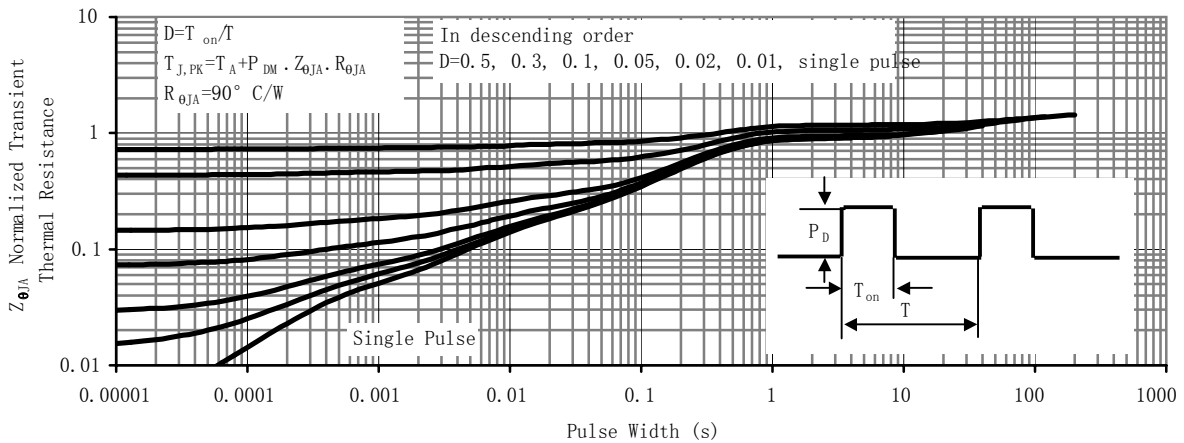
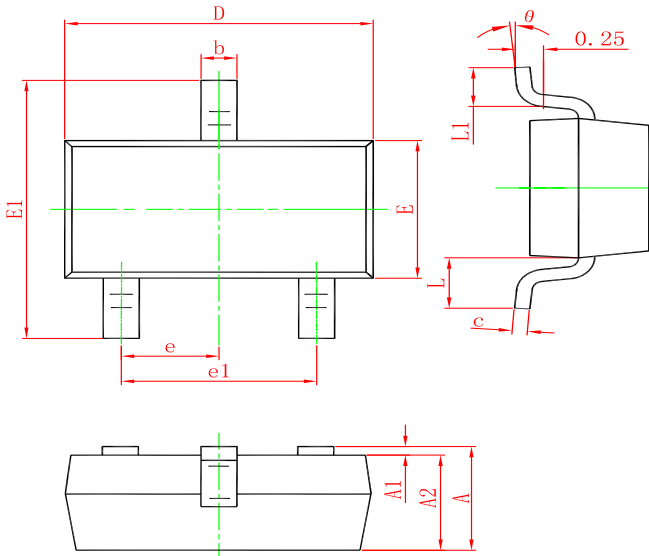

Figure 11: Normalized Maximum Transient Thermal Impedance

SOT-23 PACKAGE OUTLINE DIMENSIONS



| Symbol | Dimensions In Millimeters | | Dimensions In Inches | |
|--------|---------------------------|-------|----------------------|-------|
| | Min. | Max. | Min. | Max. |
| A | 0.900 | 1.150 | 0.035 | 0.045 |
| A1 | 0.000 | 0.100 | 0.000 | 0.004 |
| A2 | 0.900 | 1.050 | 0.035 | 0.041 |
| b | 0.300 | 0.500 | 0.012 | 0.020 |
| c | 0.080 | 0.150 | 0.003 | 0.006 |
| D | 2.800 | 3.000 | 0.110 | 0.118 |
| E | 1.200 | 1.400 | 0.047 | 0.055 |
| E1 | 2.250 | 2.550 | 0.089 | 0.100 |
| e | 0.950 TYP. | | 0.037 TYP. | |
| e1 | 1.800 | 2.000 | 0.071 | 0.079 |
| L | 0.550 REF. | | 0.022 REF. | |
| L1 | 0.300 | 0.500 | 0.012 | 0.020 |
| θ | 0° | 8° | 0° | 8° |

Marking

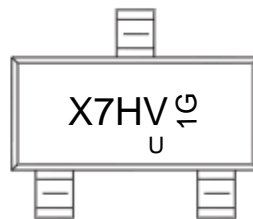

Ordering information

| Order code | Package | Baseqty | Deliverymode |
|------------|---------|---------|---------------|
| AO3407A | SOT-23 | 3000 | Tape and reel |