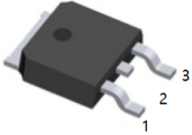
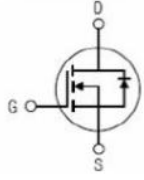

<p>General Description</p> <p>These N-channel enhancement mode power mosfets used advanced trench technology design, provided excellent Rdson and low gate charge. Which accords with the RoHS standard.</p> <p>Features</p> <ul style="list-style-type: none"> ● $V_{DS} = 60V, I_D = 25A$ ● $R_{DS(ON), 23 m\Omega (Typ) @ V_{GS} = 10V}$ ● $R_{DS(ON), 30 m\Omega (Typ) @ V_{GS} = 4.5V}$ ● Fast Switching ● Low ON Resistance($R_{dson} \leq 29m\Omega$) ● Low Gate Charge ● Low Reverse transfer capacitances ● 100% Single Pulse avalanche energy Test <p>Application</p> <ul style="list-style-type: none"> ● Power switch circuit of adaptor and charger; ● LED backlight driver; ● Synchronourectification 	<div style="text-align: center;">  <p>1.Date 2.Drain 3.Source TO-252(DPAK) top view</p> </div> <div style="text-align: center; margin-top: 20px;"> <p>Inner Equivalent Principium Chart</p>  </div>
---	---

Package Marking and Ordering Information

Device Marking	Device	Device Package	Reel Size	Tape width	Quantity
25N06	25N06	TO-252	330mm	12mm	2500

Absolute Maximum Ratings(TA=25°C unless otherwise noted)

Parameter		Symbol	Value	Unit
Drain-Source Voltage		V_{DS}	60	V
Gate-Source Voltage		V_{GS}	± 20	V
Continuous Drain Current	TC=25°C	I_D	25	A
	TC=100°C		17.5	A
Pulsed Drain Current ¹⁾		I_{DM}	100	A
Single Puise Avalanche Energy ²⁾		E_{AS}	56.2	mJ
Maximum Power Dissipation	TC=25°C	P_D	36.2	W
Storage Temperature Range		T_{STG}	-55 to +150	°C
Operating Junction Temperature Range		T_J	-55 to +150	°C

Thermal Resistance

Parameter	Symbol	Min.	Typ.	Max	Unit
Thermal Resistance,Junction-to-Case	$R_{\theta JC}$	-	-	3.45	°C/W
Thermal Resistance,Junction to Ambient	$R_{\theta JA}$	-	-	111.5	°C/W

Electrical Characteristics(T_J=25°C unless otherwise noted)

OFF CHARACTERISTICS						
Parameter	Symbol	Conditions	Min.	Typ.	Max.	Unit
Drain-Source Breakdown Voltage	BV _{DSS}	V _{GS} =0V, I _{DS} =250uA	60	-	-	V
Zero Gate Voltage Drain Current	I _{DSS}	V _{DS} =60V, V _{GS} =0V	-	-	1	uA
Gate-Body Leakage	I _{GSS}	V _{GS} =±20V, V _{DS} =0V	-	-	±100	nA

ON CHARACTERISTICS						
Parameter	Symbol	Conditions	Min.	Typ.	Max.	Unit
Gate Threshold Voltage	V _{GS(TH)}	V _{DS} =V _{GS} , I _{DS} =250uA	1	1.5	2	V
Drain-Source On-State Resistance	R _{DS(ON)}	V _{GS} =10V, I _{DS} =19A	-	23	29	mΩ
		V _{GS} =4.5V, I _{DS} =19A	-	30	38	mΩ

DYNAMIC CHARACTERISTICS						
Parameter	Symbol	Conditions	Min.	Typ.	Max.	Unit
Input Capacitance	C _{ISS}	V _{DS} = 30V, V _{GS} = 0V, f=1MHz	-	939	-	pF
Output Capacitance	C _{OSS}		-	73.5	-	
Reverse Transfer Capacitance	C _{rss}		-	52.7	-	
Gate Resisitance	R _g	V _{DD} =0V, V _{GS} =0V, F=1MHz	-	1.9	-	Ω

SWITCHING CHARACTERISTICS						
Parameter	Symbol	Conditions	Min.	Typ.	Max.	Unit
Turn-On Delay Time	T _{d(on)}	V _{GS} =10V, V _{DS} =30V, R _{GEN} =3Ω I _D =20A	-	8.4	-	ns
Rise Time	t _r		-	8.5	-	
Turn-Off Delay Time	T _{d(off)}		-	35.4	-	
Fall Time	t _f		-	4.8	-	
Total Gate Charge	Q _g	V _{DS} =30V, I _{DS} =20A, V _{GS} =10V	-	21.2	-	nC
Gate to Source Gate Charge	Q _{gs}		-	3.6	-	
Gate to Drain "Miller" Charge	Q _{gd}		-	5.5	-	

DRAIN-SOURCE DIODE CHARACTERISTICS AND MAXIMUM RATINGS						
Parameter	Symbol	Conditions	Min.	Typ.	Max.	Unit
Drain-Source Diode Forward Voltage	V _{SD}	V _{GS} =0V, I _{DS} =20A	-	-	1.2	V
Reverse Recovery Time	t _{rr}	T _J =25°C, I _F =20A	-	18.8	-	nS
Reverse Recovery Charge	Q _{rr}	di/dt=100A/us	-	13.4	-	nC

Notes:

- 1) Repetitive rating; pulse width limited by maximum junction temperature .
- 2) L=0.5mH, V_{DD}=30V, I_{as}=15A Start T_J=25°C
- 3) Recommend soldering temperature defined by IPC/JEDEC J-STD 020

Characteristics Curve:

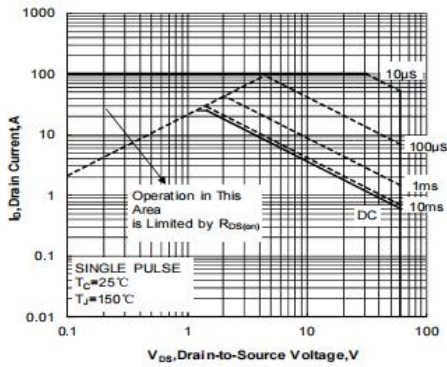

Figure 1 . Maximum Safe Operating Area

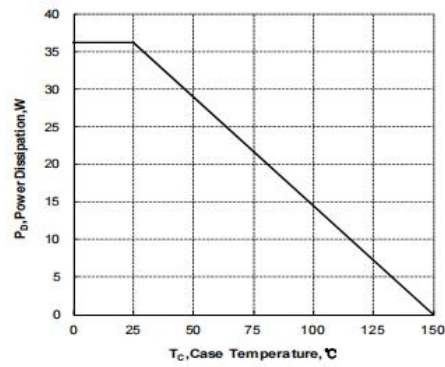

Figure 2. Maximum Power Dissipation vs Case Temperature

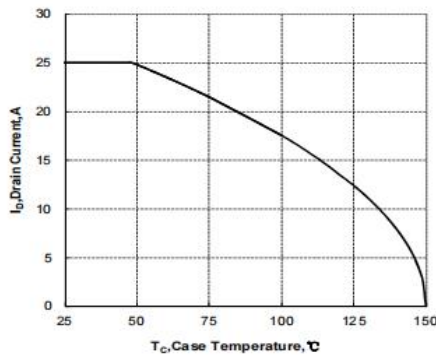

Figure 3. Maximum Continuous Drain Current vs Case Temperature

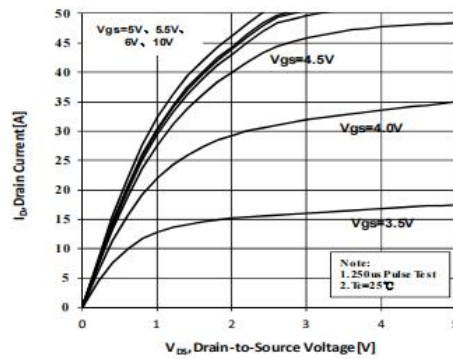

Figure 4. Typical output Characteristics

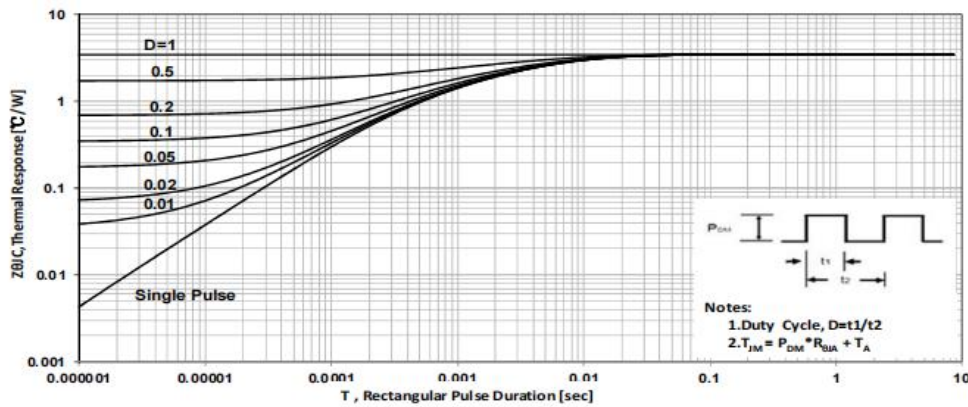

Figure 5 Maximum Effective Thermal Impedance , Junction to Case

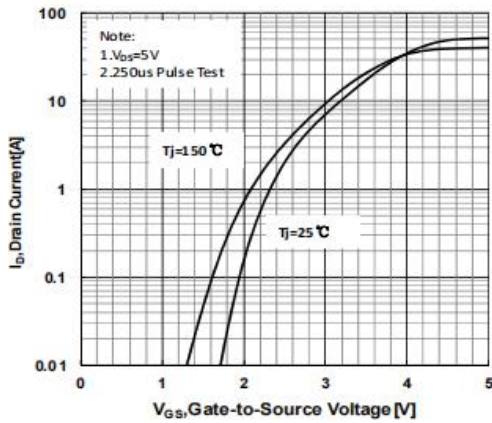

Figure 6 Typical Transfer Characteristics

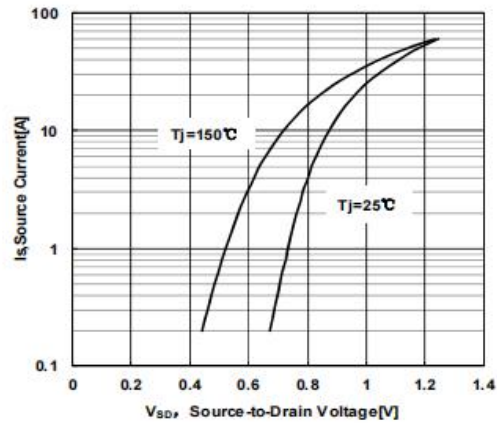

Figure 7 Typical Body Diode Transfer Characteristics

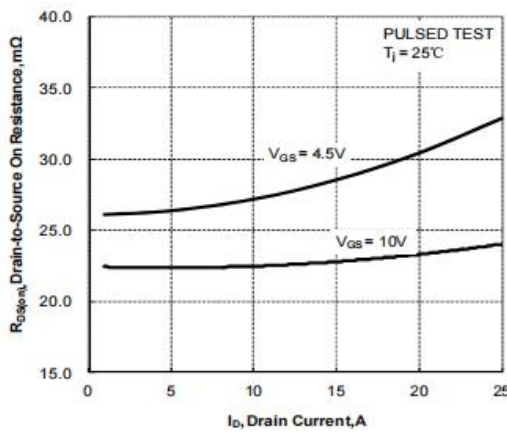

Figure 8. Drain-to-Source On Resistance vs Drain Current

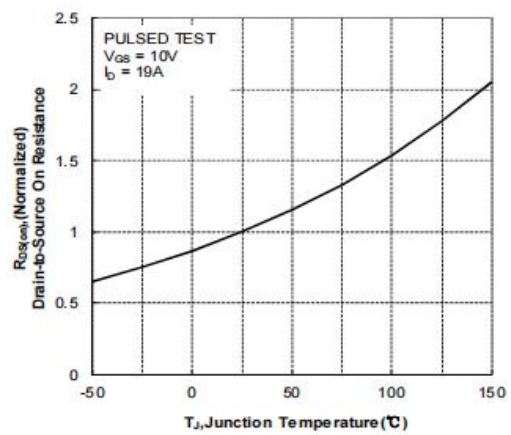

Figure 9. Normalized On Resistance vs Junction Temperature

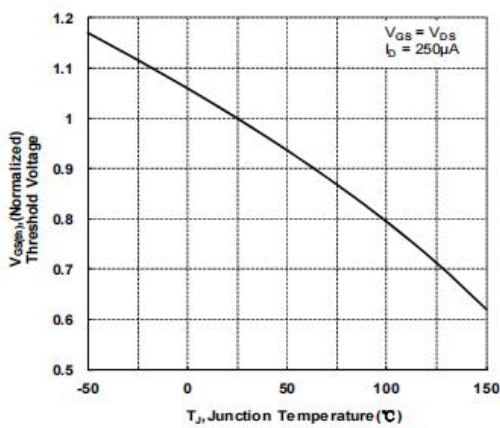

Figure 10. Normalized Threshold Voltage vs Junction Temperature

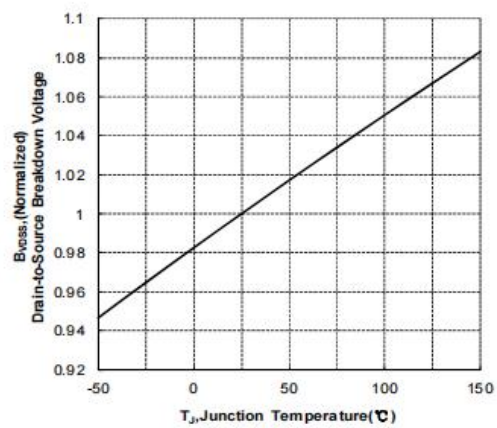

Figure 11. Normalized Breakdown Voltage vs Junction Temperature

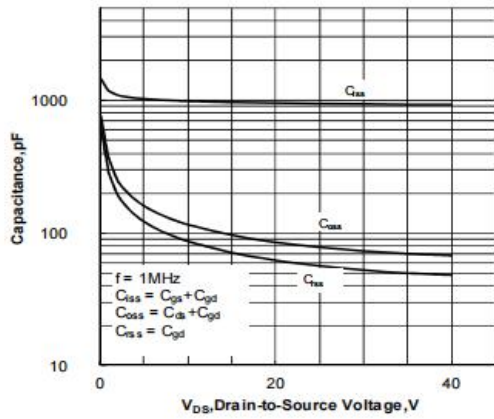

Figure 12. Capacitance Characteristics

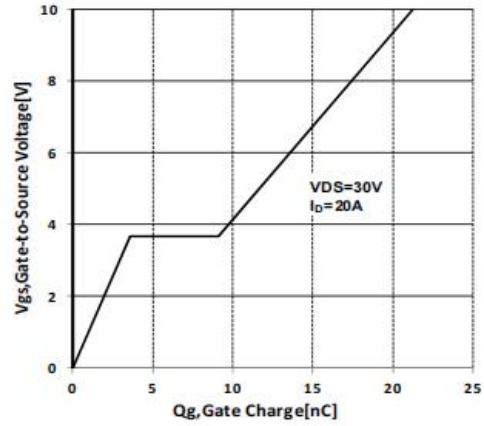

Figure 13 Typical Gate Charge vs Gate to Source Voltage

Test Circuit and Waveform

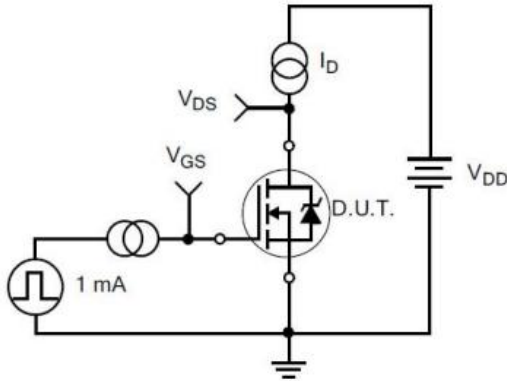

Figure 14. Gate Charge Test Circuit

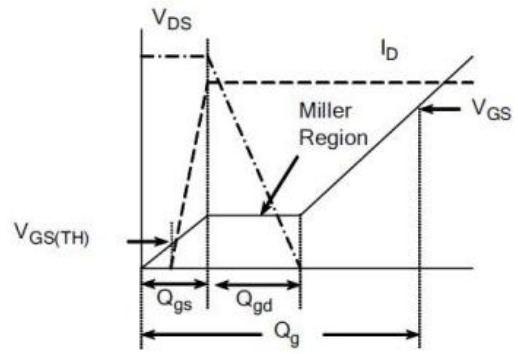

Figure 15. Gate Charge Waveforms

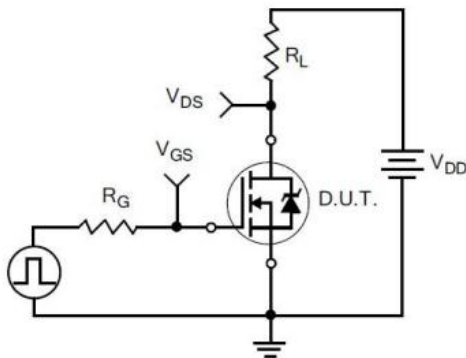

Figure 16. Resistive Switching Test Circuit

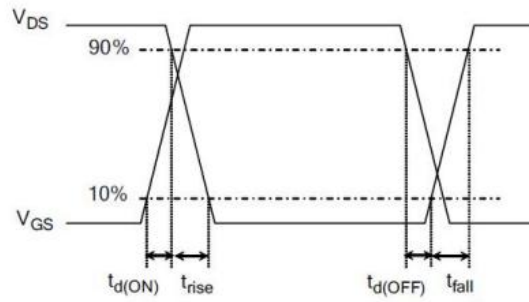

Figure 17. Resistive Switching Waveforms

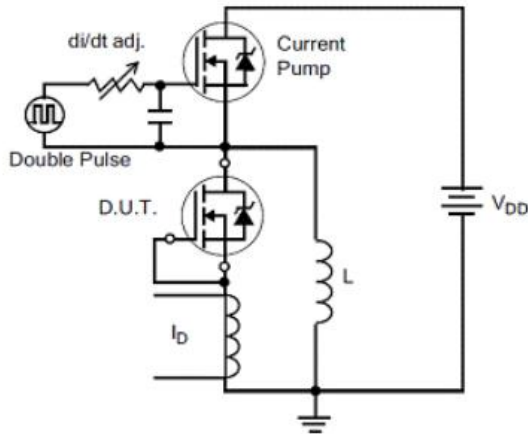

Figure 18. Diode Reverse Recovery Test Circuit

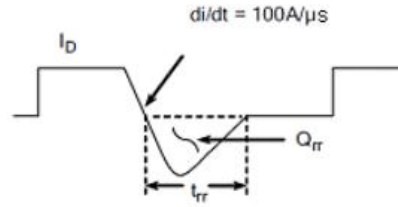

Figure 19. Diode Reverse Recovery Waveform

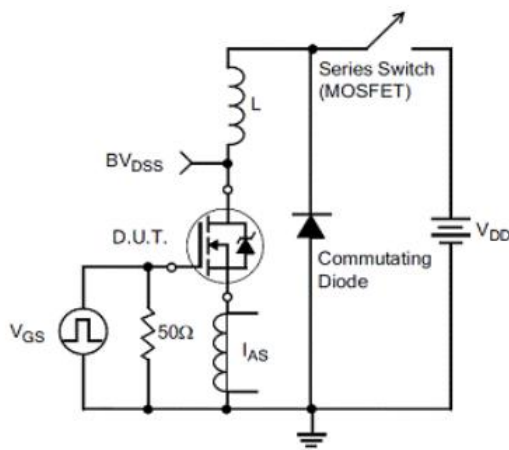

Figure20. Unclamped Inductive Switching Test Circuit

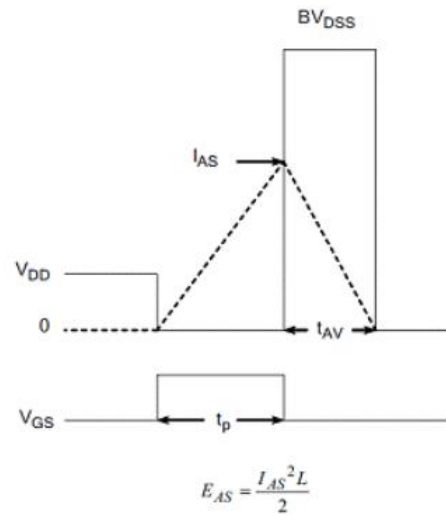
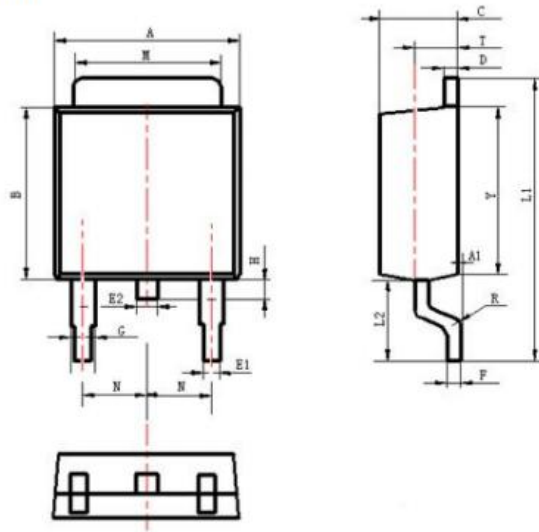

Figure21. Unclamped Inductive Switching Waveform

Package Information:



Items	Values(mm)	
	MIN	MAX
A	6.30	6.90
A1	0	0.16
B	5.70	6.30
C	2.10	2.50
D	0.30	0.70
E1	0.60	0.90
E2	0.70	1.00
F	0.30	0.60
G	0.70	1.20
L1	9.60	10.50
L2	2.70	3.10
H	0.40	1.00
M	5.10	5.50
N	2.09	2.49
R	0.3	
T	1.40	1.60
Y	5.10	6.30

TO-252 Package