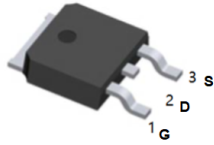
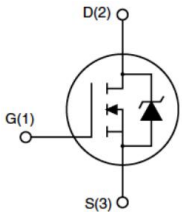

<p>General Description</p> <p>The STD10NF10 uses advanced trench technology to provide excellent $R_{DS(ON)}$, low gate charge and operation with gate voltages as low as 4.5V. This device is suitable for use as a wide variety of applications.</p> <p>Features</p> <ul style="list-style-type: none"> ● $V_{DS} = 100V, I_D = 15A$ ● $R_{DS(ON)}, 95\text{ m}\Omega$ (Typ) @ $V_{GS} = 10V$ ● $R_{DS(ON)}, 100\text{ m}\Omega$ (Typ) @ $V_{GS} = 4.5V$ ● Low Total Gate Charge ● Low Reverse Transfer Capacitance ● Improved dv/dt Capability ● Fast Switching Speed <p>Application</p> <ul style="list-style-type: none"> ● Uninterruptible Power Supply(UPS) ● Inverter System 	<div style="text-align: center;">  <p>TO-252(DPAK) top view</p> </div> <div style="text-align: center; margin-top: 20px;">  </div>
--	---

Absolute Maximum Ratings($T_A=25^\circ\text{C}$ unless otherwise noted)

Parameter	Symbol	Value	Unit
Drain-Source Voltage	V_{DS}	100	V
Gate-Source Voltage	V_{GS}	± 20	V
Drain Current-Continuous	I_D	TC=25 $^\circ\text{C}$	15
		TC=100 $^\circ\text{C}$	10
Drain Current-Pulsed ^{Note2}	I_{DM}	60	A
Maximum Power Dissipation	P_D	55	W
Storage Temperature Range	T_{STG}	-55 to +175	$^\circ\text{C}$
Operating Junction Temperature Range	T_J	-55 to +175	$^\circ\text{C}$

Thermal Resistance

Parameter	Symbol	Min.	Typ.	Max	Unit
Thermal Resistance, Junction-to-Case	$R_{\theta JC}$	-	2.72	-	$^\circ\text{C/W}$

100V N-Channel Power MOSFET
Electrical Characteristics(T_J=25°C unless otherwise noted)

OFF CHARACTERISTICS						
Parameter	Symbol	Conditions	Min.	Typ.	Max.	Unit
Drain-Source Breakdown Voltage	BV _{DSS}	V _{GS} =0V, I _{DS} =250uA	100	-	-	V
Zero Gate Voltage Drain Current	I _{DSS}	V _{DS} =100V, V _{GS} =0V	-	-	1	uA
Gate-Body Leakage	I _{GSS}	V _{GS} =±20V, V _{DS} =0V	-	-	±100	nA

ON CHARACTERISTICS						
Parameter	Symbol	Conditions	Min.	Typ.	Max.	Unit
Gate Threshold Voltage	V _{GS(TH)}	V _{DS} =V _{GS} , I _{DS} =250uA	1.0	1.6	3.0	V
Drain-Source On-State Resistance	R _{DS(ON)}	V _{GS} =10V, I _{DS} =10A	-	95	110	mΩ
		V _{GS} =4.5V, I _{DS} =5A	-	100	130	
Forward Transconductance	g _{FS}	V _{GS} =5V, I _{DS} =4A	2	-	-	S

DYNAMIC CHARACTERISTICS						
Parameter	Symbol	Conditions	Min.	Typ.	Max.	Unit
Input Capacitance	C _{ISS}	V _{DS} = 50V, V _{GS} = 0V, f=1MHz	-	632	-	pF
Output Capacitance	C _{OSS}		-	37	-	
Reverse Transfer Capacitance	C _{rss}		-	21	-	

SWITCHING CHARACTERISTICS						
Parameter	Symbol	Conditions	Min.	Typ.	Max.	Unit
Turn-On Delay Time	T _{d(on)}	V _{GS} =10V, V _{DS} =50V, R _L =2.8Ω, R _{GEN} =6Ω, I _D =10A	-	12.6	-	ns
Rise Time	t _r		-	6	-	
Turn-Off Delay Time	T _{d(off)}		-	32.5	-	
Fall Time	t _f		-	4.3	-	
Total Gate Charge at 10V	Q _g	V _{DS} =80V, I _{DS} =10A, V _{GS} =10V	-	19.2	-	nC
Gate to Source Gate Charge	Q _{gs}		-	3.4	-	
Gate to Drain "Miller" Charge	Q _{gd}		-	6.1	-	

DRAIN-SOURCE DIODE CHARACTERISTICS AND MAXIMUM RATINGS						
Parameter	Symbol	Conditions	Min.	Typ.	Max.	Unit
Drain-Source Diode Forward Voltage	V _{SD}	V _{GS} =0V, I _{DS} =10A	-	-	1.2	V

Notes 1. The maximum current rating is package limited.

Notes 2. Repetitive Rating: Pulse width limited by maximum junction temperature

Notes 3. EAS condition: T_J=25°C, V_{DD}=50V, V_G=10V, R_G=25Ω

Typical Performance Characteristics

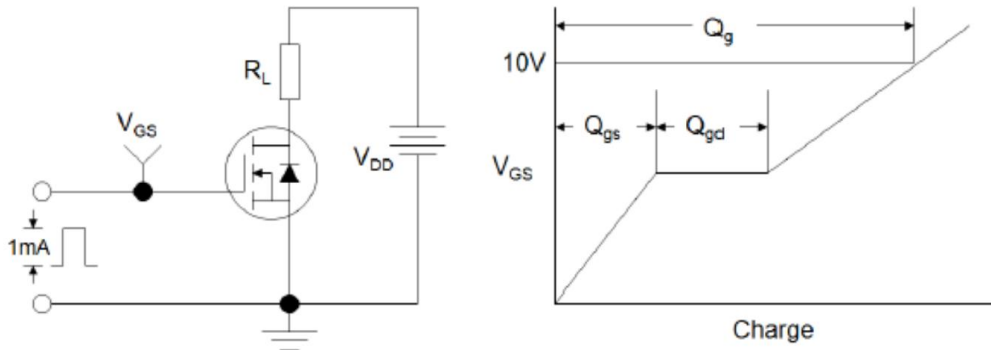

Figure1:Gate Charge Test Circuit & Waveform

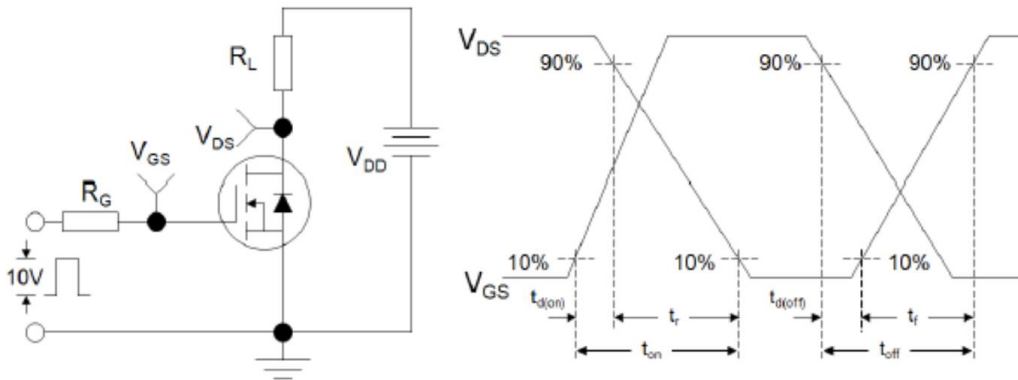

Figure 2: Resistive Switching Test Circuit & Waveforms

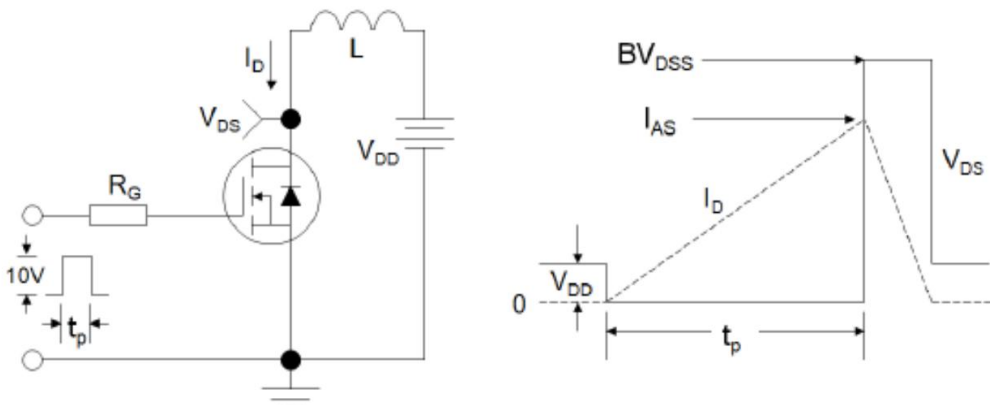

Figure 3:Unclamped Inductive Switching Test Circuit & Waveforms

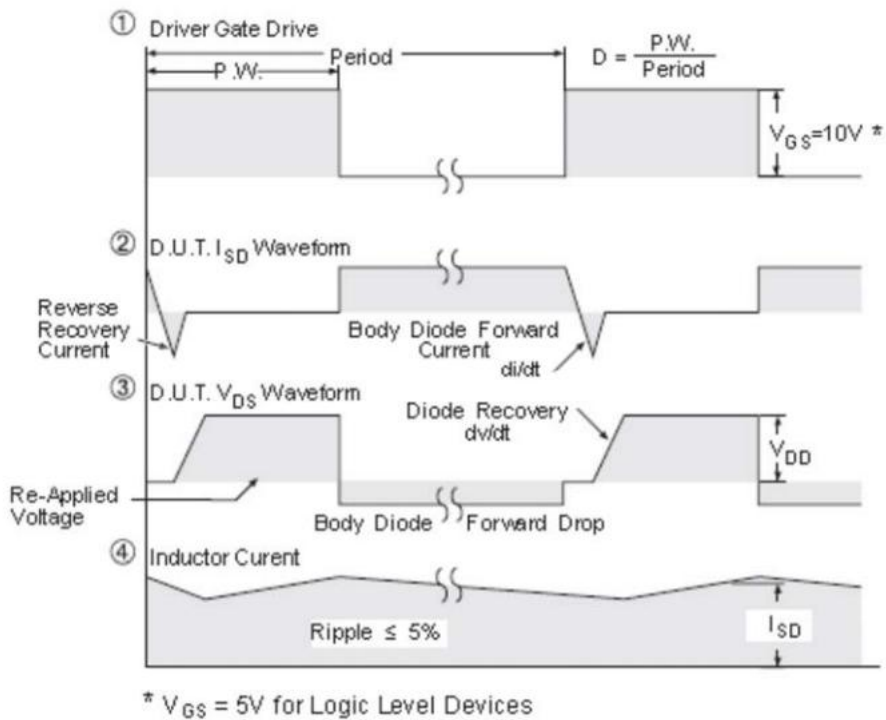
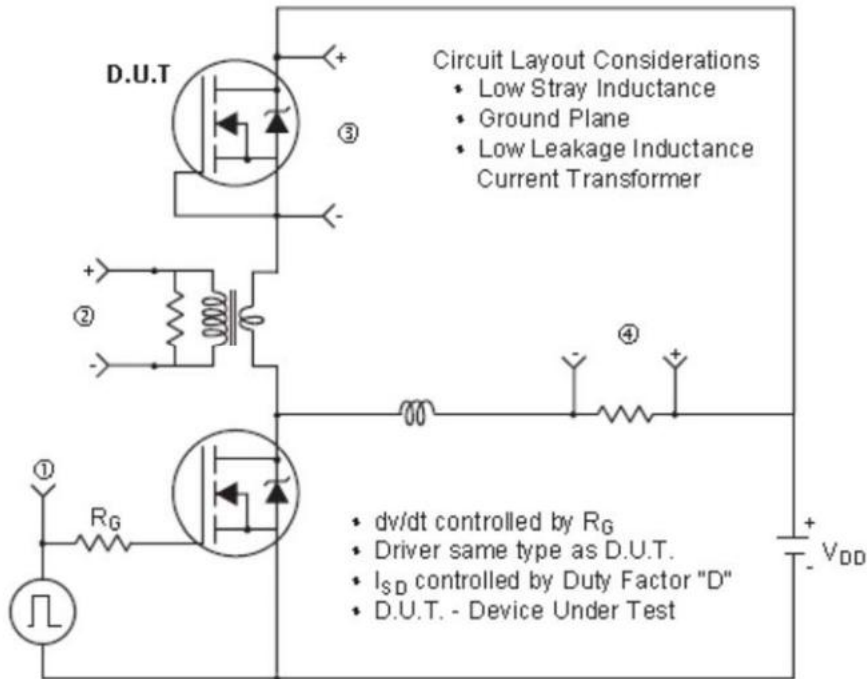
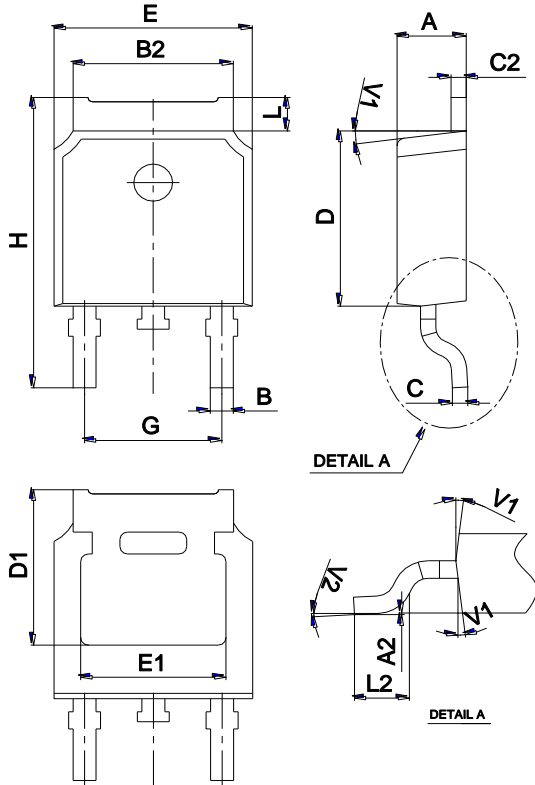

Figure 4: Peak Diode Recovery dv/dt Test Circuit & Waveforms (For N-channel)

Package Mechanical Data TO-252



Ref.	Dimensions					
	Millimeters			Inches		
	Min.	Typ.	Max.	Min.	Typ.	Max.
A	2.10		2.50	0.083		0.098
A2	0		0.10	0		0.004
B	0.66		0.86	0.026		0.034
B2	5.18		5.48	0.202		0.216
C	0.40		0.60	0.016		0.024
C2	0.44		0.58	0.017		0.023
D	5.90		6.30	0.232		0.248
D1	5.30REF			0.209REF		
E	6.40		6.80	0.252		0.268
E1	4.63			0.182		
G	4.47		4.67	0.176		0.184
H	9.50		10.70	0.374		0.421
L	1.09		1.21	0.043		0.048
L2	1.35		1.65	0.053		0.065
V1		7°			7°	
V2	0°		6°	0°		6°

Ordering information

Order code	Package	Baseqty	Delivery mode
STD10NF10L	TO-252	2500	Tape and reel