

SOT-23 Plastic-Encapsulate MOSFETS

IRLML5203 P-Channel 30-V(D-S) MOSFET

$V_{(BR)DSS}$	$R_{DS(on)MAX}$	I_D
-30V	85mΩ@-10 V	-3.0A
	145mΩ@-4.5V	

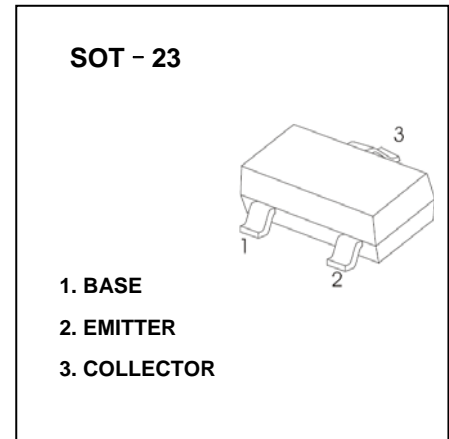

General Description

The IRLML5203 uses advanced trench technology to provide excellent $R_{DS(on)}$ with low gate charge. This device is suitable for use as a load switch or in PWM applications.

MARKING

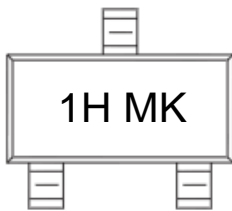

Equivalent Circuit

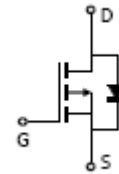

Maximum ratings ($T_a=25^{\circ}C$ unless otherwise noted)

Parameter	Symbol	Value	Units
Drain-Source voltage	V_{DS}	-30	V
Gate-Source Voltage	V_{GS}	±20	V
Continuous Drain Current	I_D	-3.0	A
Drain Current-Pulsed	I_{DM}	-24	A
Power Dissipation	P_D	300	mW
Thermal Resistance from Junction to Ambient	$R_{\theta JA}$	417	$^{\circ}C/W$
Junction Temperature	T_J	150	$^{\circ}C$
Storage Temperature	T_{STG}	-55~ +150	$^{\circ}C$

SOT-23 Plastic-Encapsulate MOSFETS
T_a=25 °C unless otherwise specified

Parameter	Symbol	Test Condition	Min	Typ	Max	Unit
Static characteristics						
Drain-source breakdown voltage	V _{(BR) DSS}	V _{GS} = 0V, I _D = -250μA	-30			V
Zero gate voltage drain current	I _{DSS}	V _{DS} = -24V, V _{GS} = 0V			-1	μA
Gate -source leakage current	I _{GSS}	V _{GS} = ±20V, V _{DS} = 0V			±100	nA
Drain-source on-resistance (note 1)	R _{DS(on)}	V _{GS} = -10V, I _D = -4.1A			85	mΩ
		V _{GS} = -4.5V, I _D = -3A			145	mΩ
Forward tranconductance (note 1)	g _{FS}	V _{DS} = -5V, I _D = -4A	5.5			S
Gate threshold voltage	V _{GS(th)}	V _{DS} = V _{GS} , I _D = -250μA	-1		-3	V
Diode forward voltage (note 1)	V _{SD}	I _S = -1A, V _{GS} = 0V			-1	V
Dynamic characteristics (note 2)						
Input capacitance	C _{iss}	V _{DS} = -15V, V _{GS} = 0V, f = 1MHz		700		pF
Output capacitance	C _{oss}			120		pF
Reverse transfer capacitance	C _{rss}			75		pF
Switching characteristics (note 2)						
Turn-on delay time	t _{d(on)}	V _{GS} = -10V, V _{DS} = -15V, R _L = 3.6Ω, R _{GEN} = 3Ω		8.6		ns
Turn-on rise time	t _r			5.0		ns
Turn-off delay time	t _{d(off)}			28.2		ns
Turn-off fall time	t _f			13.5		ns

Notes:

1. Pulse test: Pulse width ≤ 300μs, Duty cycle ≤ 2%.
2. These parameter have no way to verify.

SOT-23 Plastic-Encapsulate MOSFETS

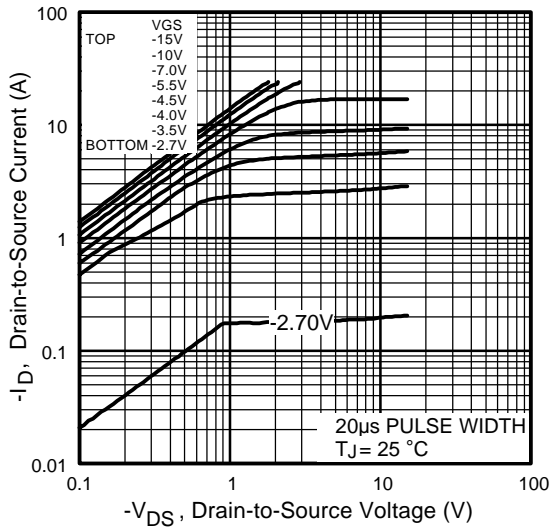

Fig 1. Typical Output Characteristics

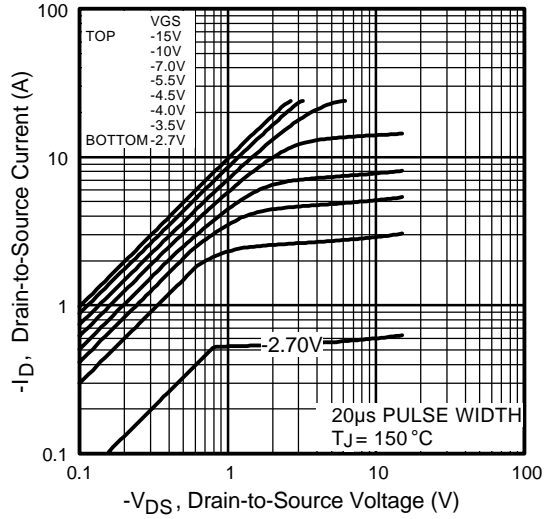

Fig 2. Typical Output Characteristics

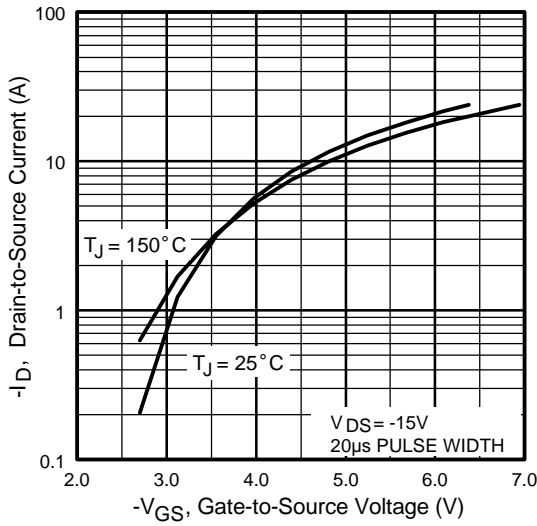

Fig 3. Typical Transfer Characteristics

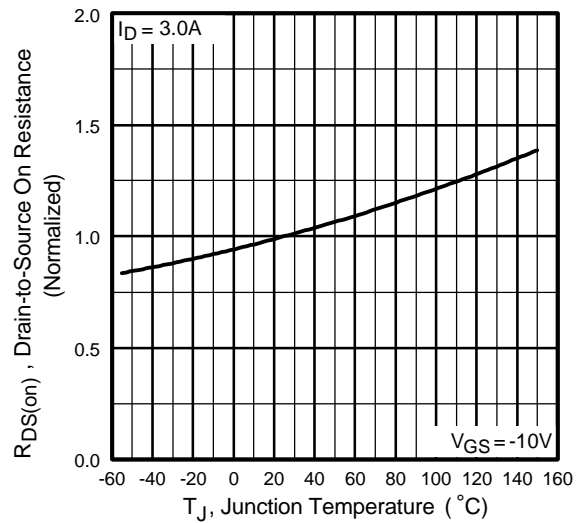

Fig 4. Normalized On-Resistance Vs. Temperature

SOT-23 Plastic-Encapsulate MOSFETS

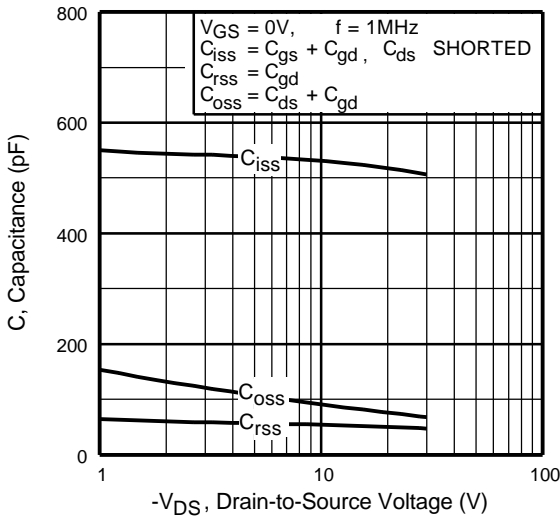

Fig 5. Typical Capacitance Vs. Drain-to-Source Voltage

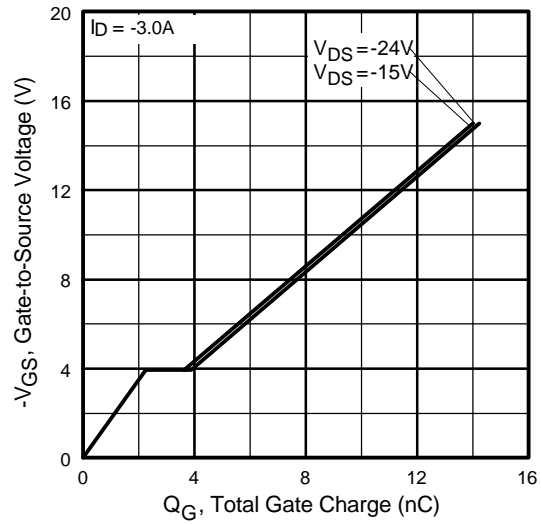

Fig 6. Typical Gate Charge Vs. Gate-to-Source Voltage

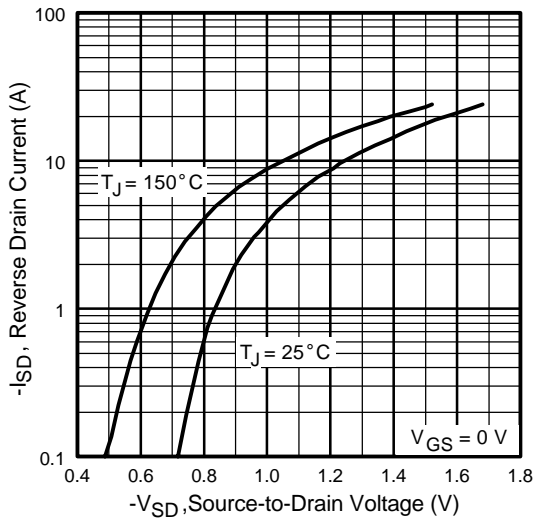

Fig 7. Typical Source-Drain Diode Forward Voltage

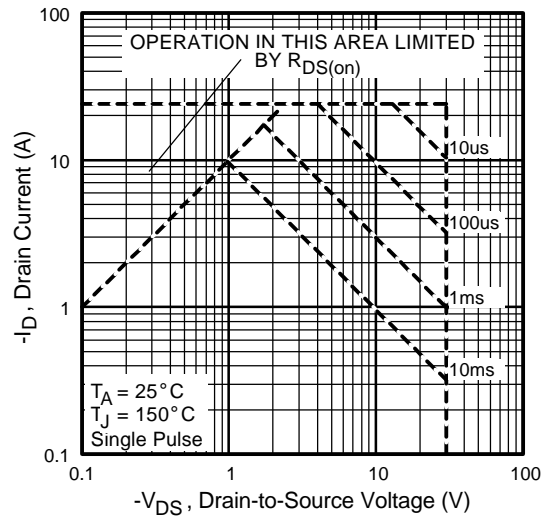

Fig 8. Maximum Safe Operating Area

SOT-23 Plastic-Encapsulate MOSFETS

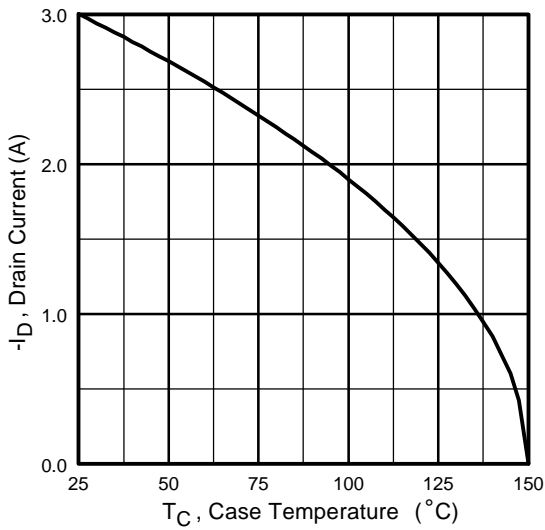

Fig 9. Maximum Drain Current Vs. Case Temperature

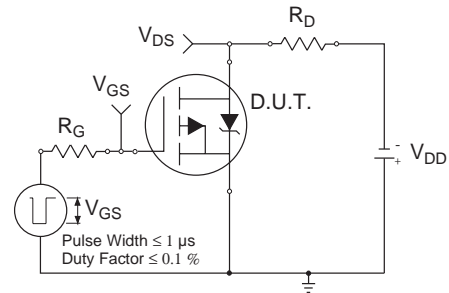

Fig 10a. Switching Time Test Circuit

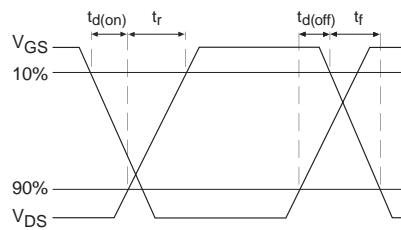

Fig 10b. Switching Time Waveforms

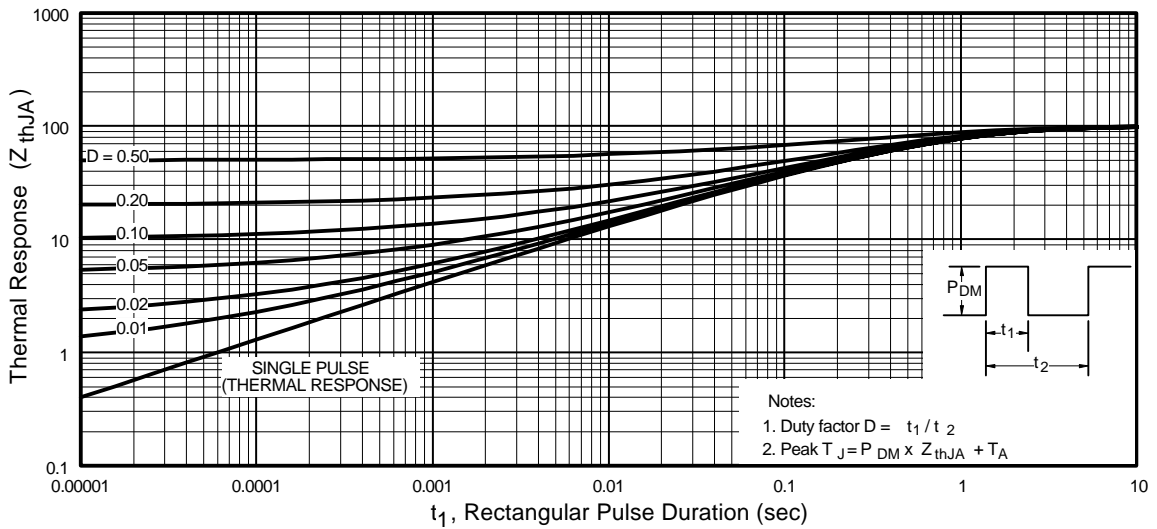

Fig 11. Maximum Effective Transient Thermal Impedance, Junction-to-Ambient

SOT-23 Plastic-Encapsulate MOSFETS

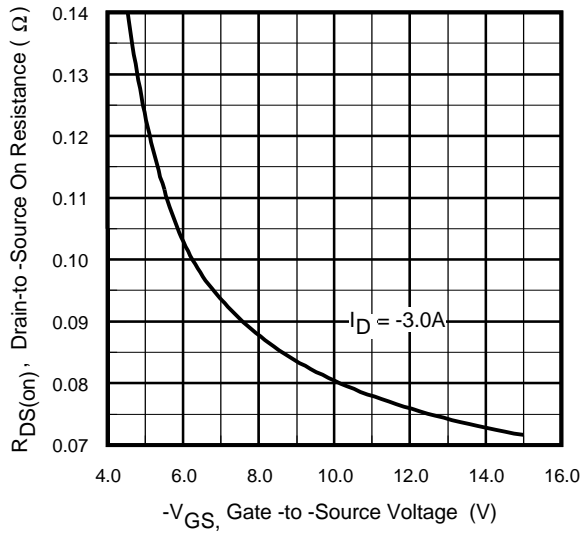

Fig 11. Typical On-Resistance Vs. Gate Voltage

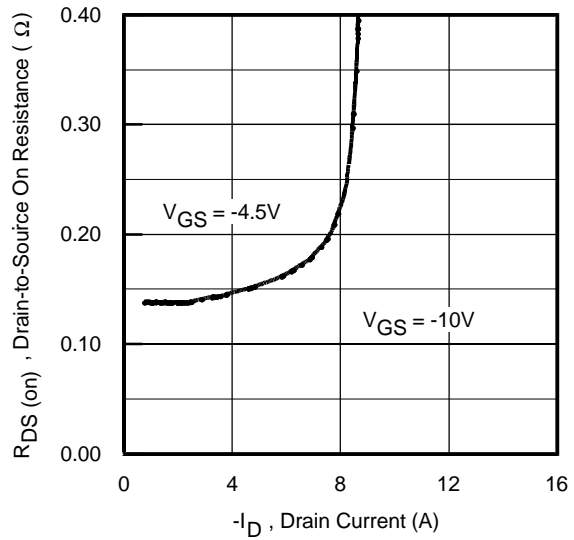

Fig 12. Typical On-Resistance Vs. Drain Current

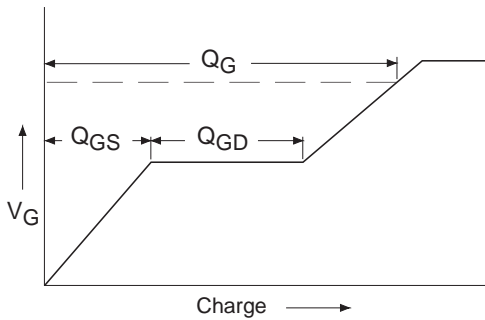

Fig 13a. Basic Gate Charge Waveform

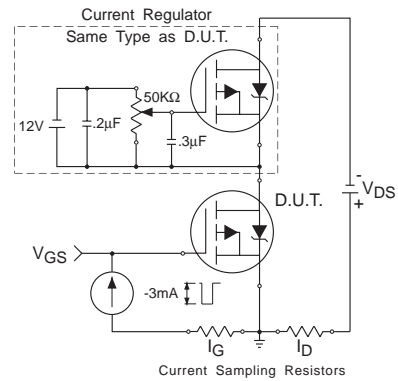

Fig 13b. Gate Charge Test Circuit

SOT-23 Plastic-Encapsulate MOSFETS

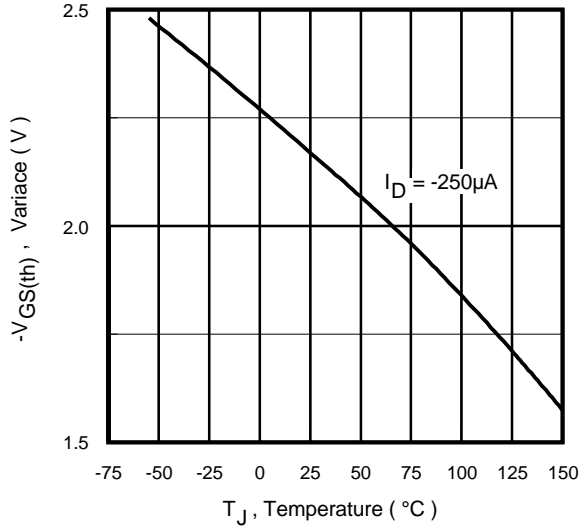

Fig 14. Threshold Voltage Vs. Temperature

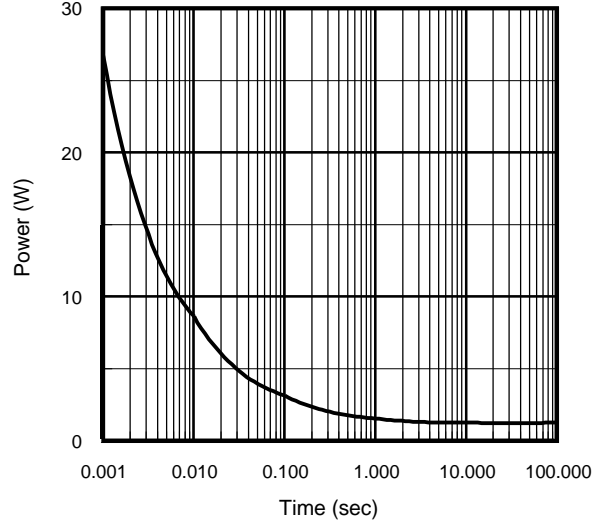
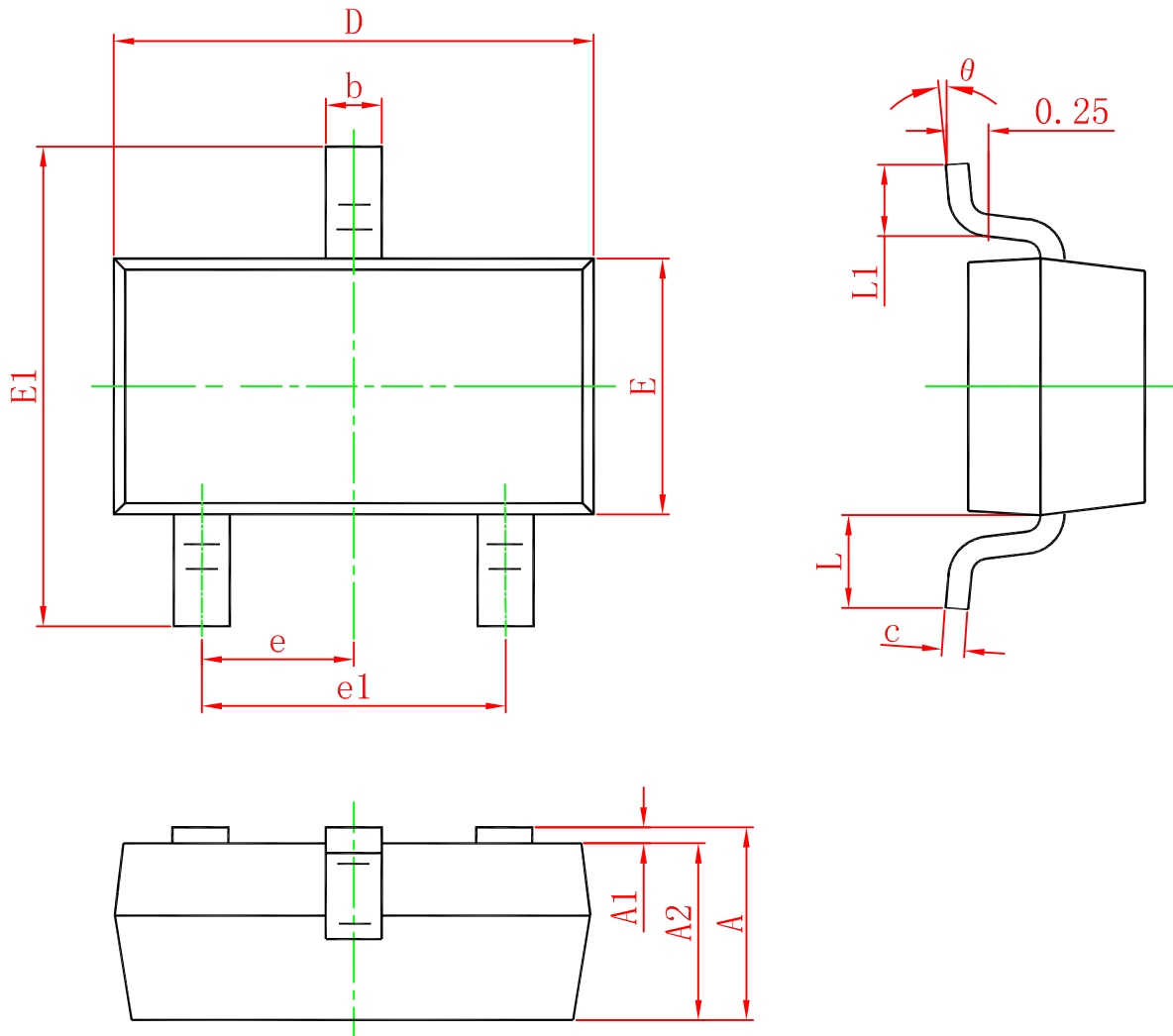

Fig 15. Typical Power Vs. Time

SOT-23 Plastic-Encapsulate MOSFETS

SOT-23 PACKAGE OUTLINE DIMENSIONS



Symbol	Dimensions In Millimeters		Dimensions In Inches	
	Min.	Max.	Min.	Max.
A	0.900	1.150	0.035	0.045
A1	0.000	0.100	0.000	0.004
A2	0.900	1.050	0.035	0.041
b	0.300	0.500	0.012	0.020
c	0.080	0.150	0.003	0.006
D	2.800	3.000	0.110	0.118
E	1.200	1.400	0.047	0.055
E1	2.250	2.550	0.089	0.100
e	0.950 TYP.		0.037 TYP.	
e1	1.800	2.000	0.071	0.079
L	0.550 REF.		0.022 REF.	
L1	0.300	0.500	0.012	0.020
θ	0°	8°	0°	8°