

2SC3356

NPN Transistors

Features

- Low noise and high gain.
NF = 1.1 dB Typ., Ga = 11 dB Typ. @V_{CE} = 10 V, I_c = 7 mA, f = 1.0 GHz
- High power gain.
MAG = 13 dB Typ. @V_{CE} = 10 V, I_c = 20 mA, f = 1.0 GHz

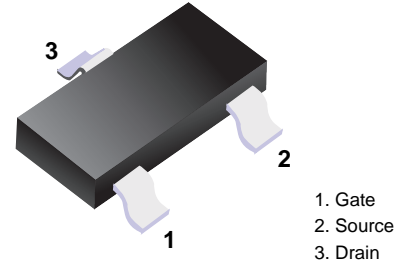

■ Simplified outline(SOT23)

Absolute Maximum Ratings Ta = 25°C

Parameter	Symbol	Rating	Unit
Collector to base voltage	V _{CB0}	20	V
Collector to emitter voltage	V _{CEO}	12	V
Emitter to base voltage	V _{EB0}	3.0	V
Collector current (DC)	I _c	100	mA
Total power dissipation	P _{tot}	200	mW
Junction temperature	T _j	150	°C
Storage temperature range	T _{stg}	-65 to +150	°C

Electrical Characteristics Ta = 25°C

Parameter	Symbol	Test Conditions	Min	Typ	Max	Unit
Collector- base breakdown voltage	V _{CB0}	I _c = 100 μA, I _E = 0	20			V
Collector- emitter breakdown voltage	V _{CEO}	I _c = 1 mA, I _B = 0	12			
Emitter - base breakdown voltage	V _{EB0}	I _E = 100 μA, I _c = 0	3			
Collector-base cut-off current	I _{CB0}	V _{CB} = 10 V, I _E = 0			1	μA
Emitter cut-off current	I _{EB0}	V _{EB} = 3V, I _c =0			1	
Collector-emitter saturation voltage *	V _{CE(sat)}	I _c =50 mA, I _B =5mA			0.4	V
Base - emitter saturation voltage *	V _{BE(sat)}	I _c =50 mA, I _B =5mA			1.2	
DC current gain *	h _{FE}	V _{CE} = 10V, I _c = 20mA	50		400	
Insertion power gain	S _{21e} ²	V _{CE} = 10 V, I _c = 20 mA, f= 1GHz		11.5		dB
Noise figure	NF	V _{CE} = 10 V, I _c = 7 mA, f= 1GHz		1.1	2	
Reverse transfer capacitance	C _{re}	V _{CB} = 10V, I _E = 0, f=1MHz		0.55	1	pF
Transition frequency	f _r	V _{CE} = 10V, I _c = 20mA		7		GHz

*. Pulse measurement: PW ≤ 350 μs, Duty Cycle ≤ 2%.

hFE Classification

Type	2SC3356-R23	2SC3356-R24	2SC3356-R25	2SC3356-R26
Range	50-100	80-160	125-250	250-400
Marking	R23	R24	R25	R26

■ Typical Characteristics

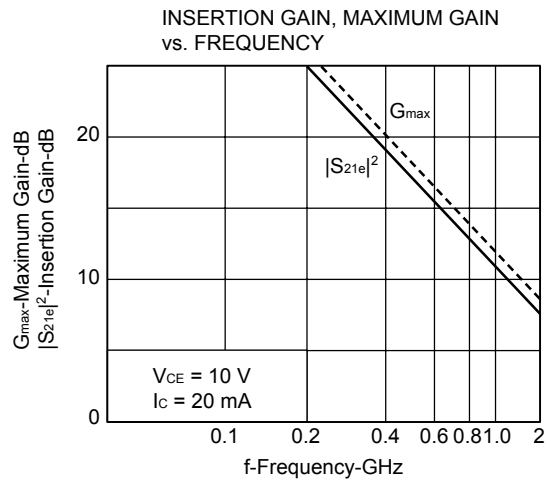
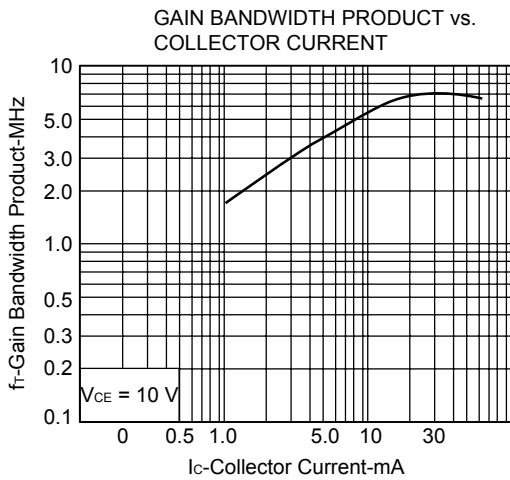
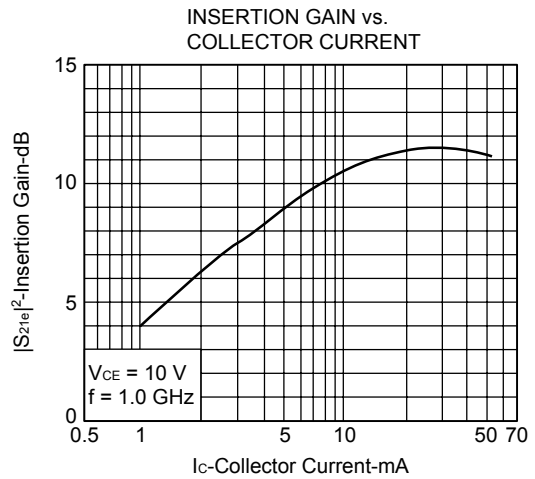
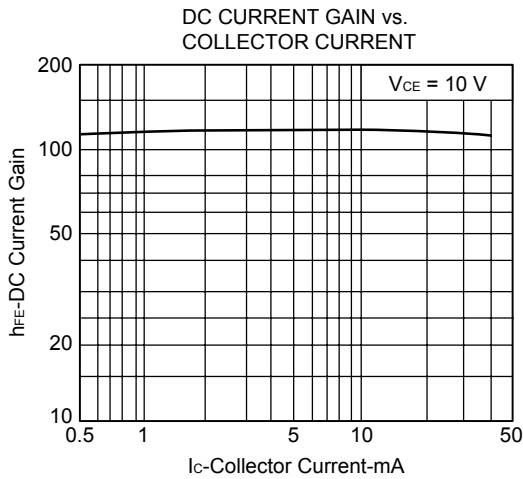
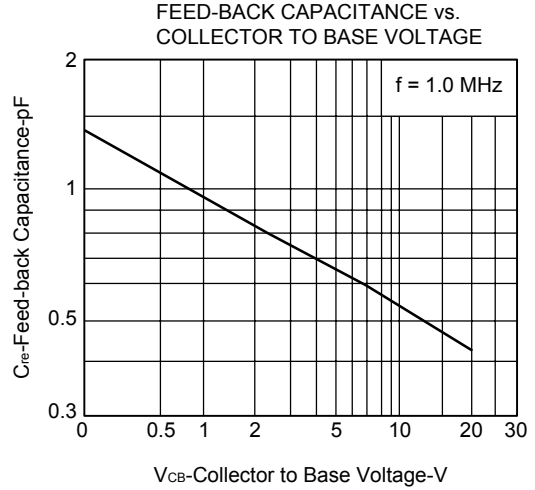
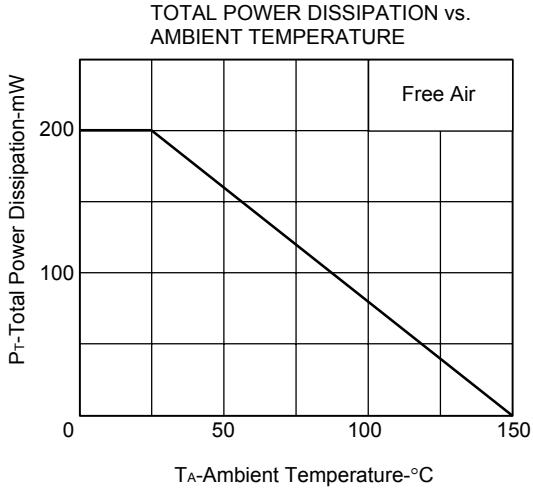

■ Typical Characteristics

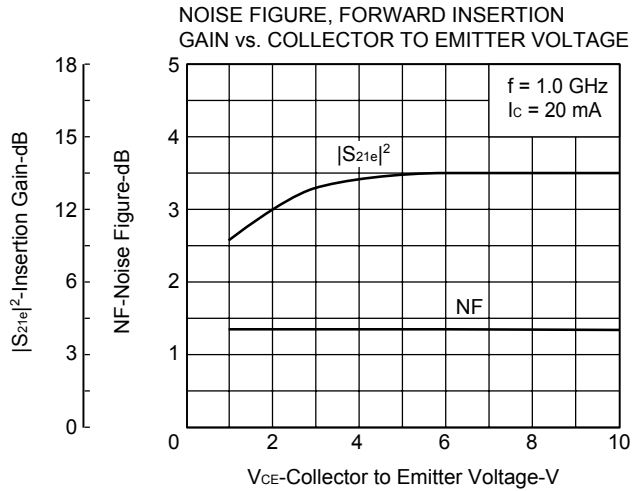
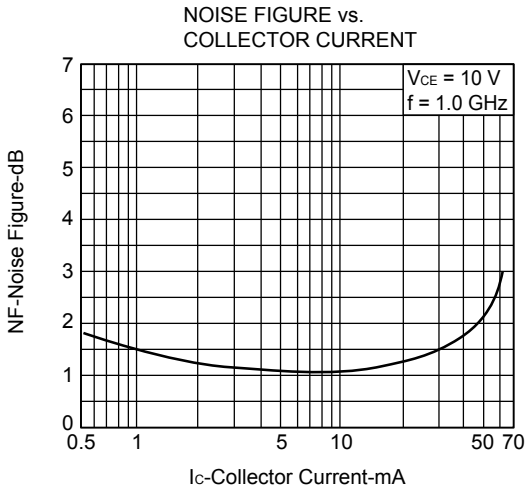

S_{11e} , S_{22e} -FREQUENCY
CONDITION $V_{CE} = 10\text{ V}$
200 MHz Step

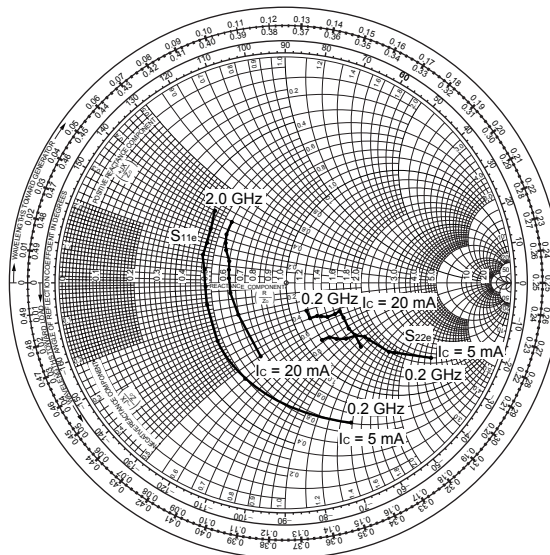

S_{21e} -FREQUENCY
CONDITION $V_{CE} = 10\text{ V}$
 $I_c = 20\text{ mA}$

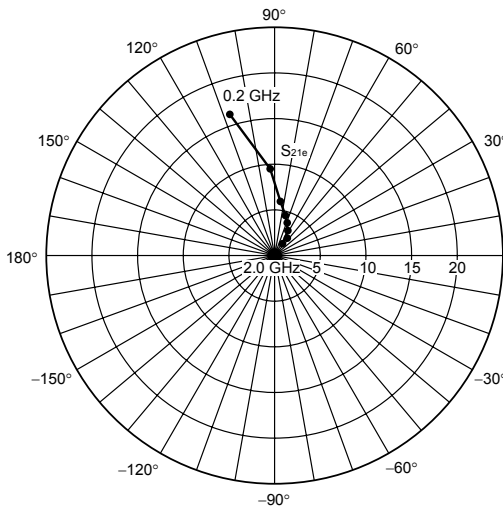

S_{12e} -FREQUENCY
CONDITION $V_{CE} = 10\text{ V}$
 $I_c = 20\text{ mA}$

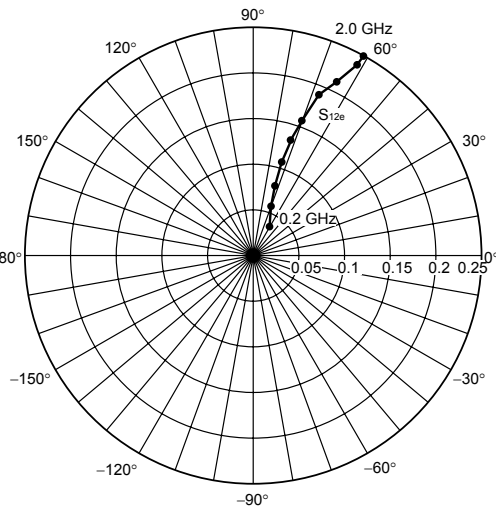

■ SOT-23

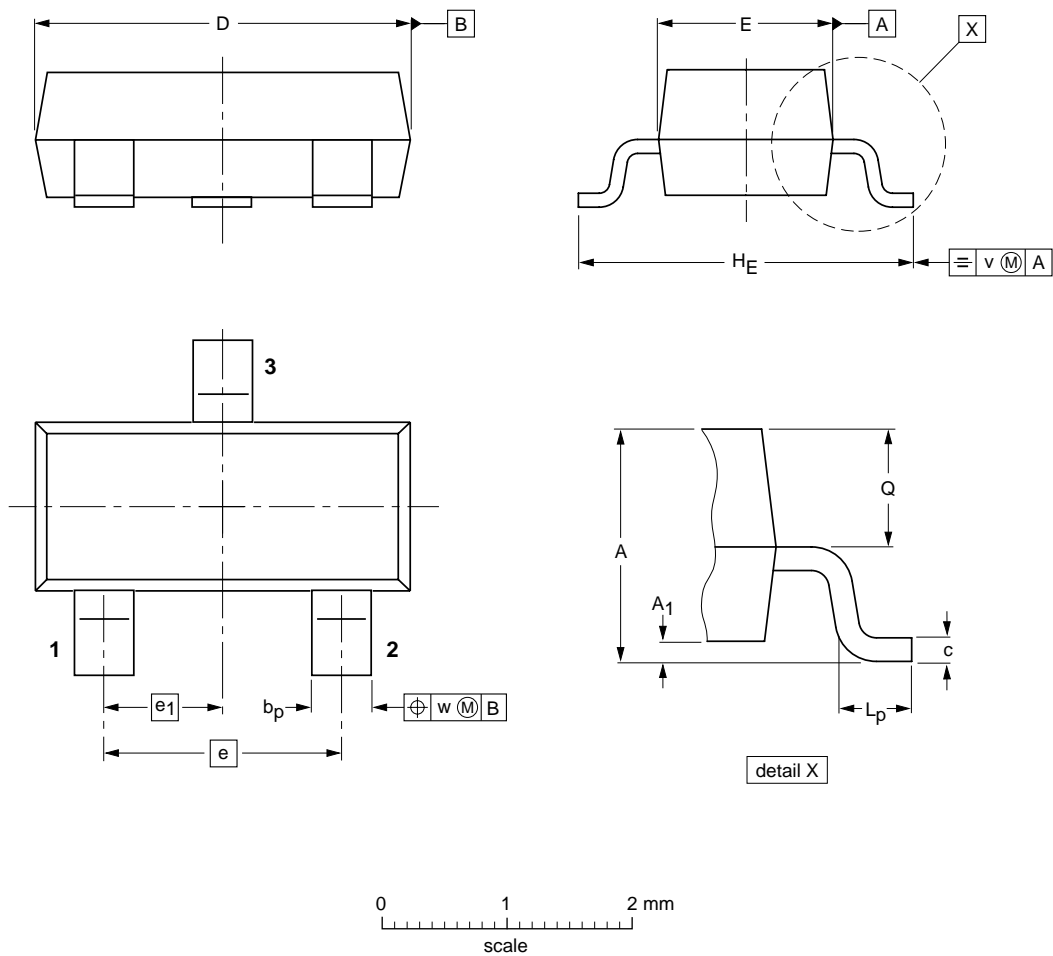

DIMENSIONS (mm are the original dimensions)

UNIT	A	A ₁ max.	b _p	c	D	E	e	e ₁	H _E	L _p	Q	v	w
mm	1.1 0.9	0.1	0.48 0.38	0.15 0.09	3.0 2.8	1.4 1.2	1.9	0.95	2.5 2.1	0.45 0.15	0.55 0.45	0.2	0.1