

## Features

- 300 W peak pulse power ( $t_p = 8/20\mu s$ )
- Bidirectional and unidirectional configurations
- Solid-state silicon-avalanche technology
- Low clamping voltage
- Low leakage current
- Low capacitance ( $C_j = 120$  pF typ.)
- Protection two data lines
- IEC 61000-4-2  $\pm 30$  kV contact  $\pm 30$  kV air
- IEC 61000-4-4 (EFT) 40A(5/50ns)
- IEC 61000-4-5 (Lightning) 20A(8/20 $\mu s$ )

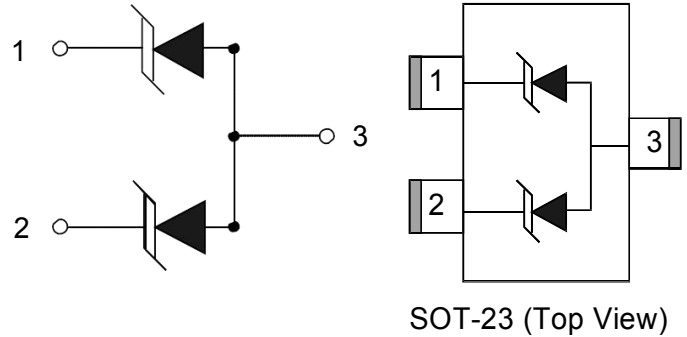

## Applications

- Dataline
- Automatic Teller Machines
- Net works
- Power line

## Mechanical Data

- SOT-23 package
- Molding compound flammability rating: UL 94V-0
- Packaging: Tape and Reel
- RoHS/WEEE Compliant

## Absolute Maximum Rating

Rating	Symbol	Value	Units
Peak Pulse Power ( $t_p = 8/20\mu s$ )	$P_{PP}$	300	W
Peak Pulse Current ( $t_p = 8/20\mu s$ ) (note1)	$I_{pp}$	20	A
ESD per IEC 61000-4-2 (Air)	$V_{ESD}$	30	kV
ESD per IEC 61000-4-2 (Contact)		30	
Lead Soldering Temperature	$T_L$	260	$^{\circ}C$
Junction Temperature	$T_J$	-55 to +125	$^{\circ}C$
Storage Temperature	$T_{stg}$	-55 to +125	$^{\circ}C$

Parameter	Symbol	Conditions	Min	Typical	Max	Units
Reverse Stand-Off Voltage	$V_{RWM}$				5	V
Reverse Breakdown Voltage	$V_{BR}$	$I_T=1mA$	6.0	7.0	8.5	V
Reverse Leakage Current	$I_R$	$V_{RWM}=5V, T=25^{\circ}C$		0.5	1	$\mu A$
Peak Pulse Current	$I_{PP}$	$t_p=8/20\mu s$			20	A
Clamping Voltage	$V_C$	$I_{PP}=10A, t_p=8/20\mu s$			12	V
		$I_{PP}=20A, t_p=8/20\mu s$			16	V
Junction Capacitance	$C_j$	$V_R = 0V, f = 1MHz$ (pin1, pin2 to pin3)		120		pF

**Electrical Parameters (TA = 25°C unless otherwise noted)**

Symbol	Parameter
$I_{PP}$	Maximum Reverse Peak Pulse Current
$V_C$	Clamping Voltage @ $I_{PP}$
$V_{RWM}$	Working Peak Reverse Voltage
$I_R$	Maximum Reverse Leakage Current @ $V_{RWM}$
$V_{BR}$	Breakdown Voltage @ $I_T$
$I_T$	Test Current

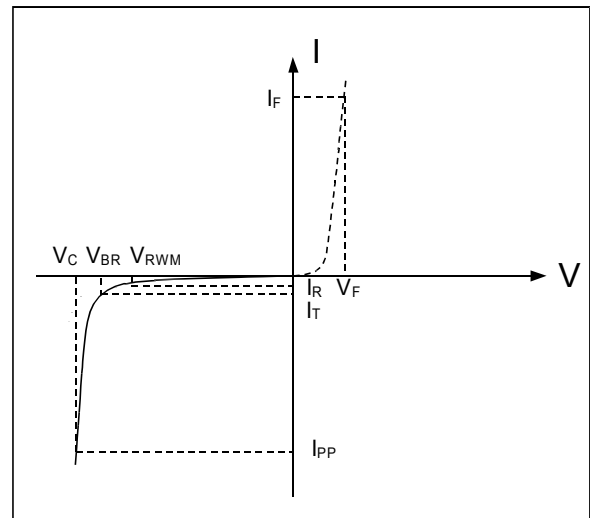

Note: 8/20 $\mu s$  pulse waveform.

## Typical Characteristics

**Figure 1: Peak Pulse Power vs. Pulse Time**

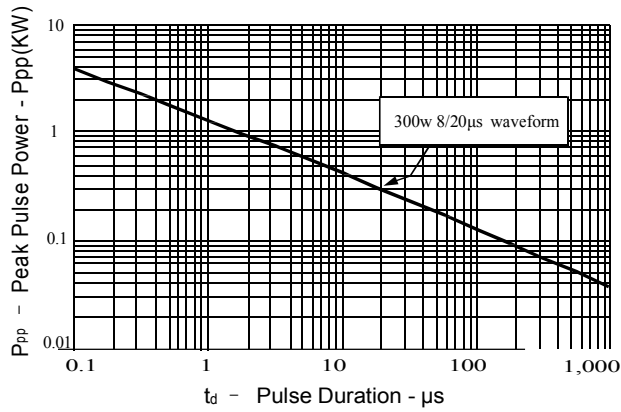

**Figure 2: Power Derating Curve**

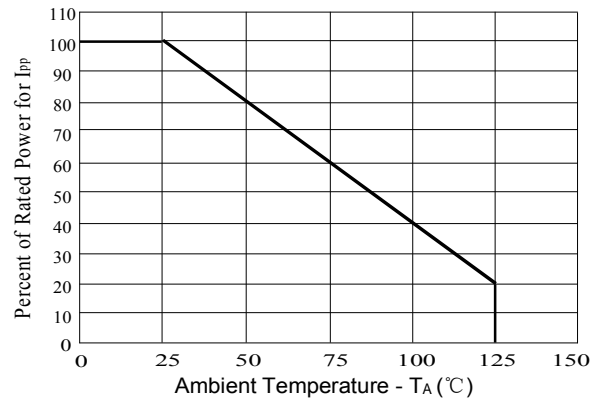

**Figure 3: Pulse Waveform**

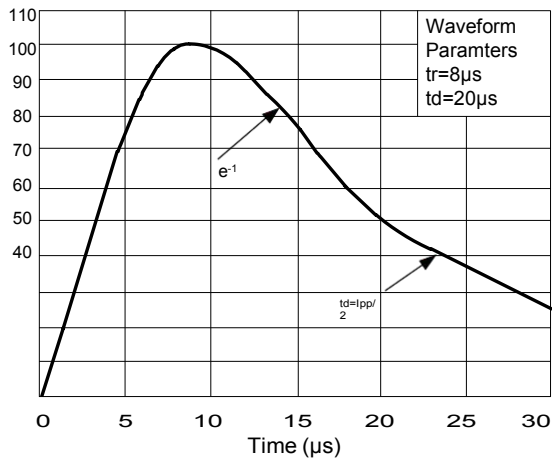

**Figure 4: Clamping Voltage vs.  $I_{pp}$**

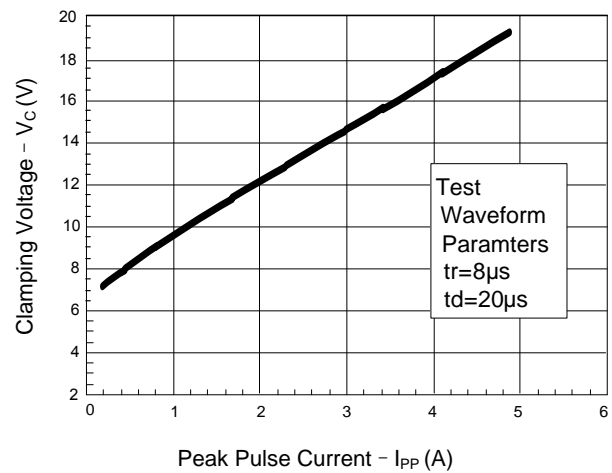

**Outline Drawing – SOT-23**

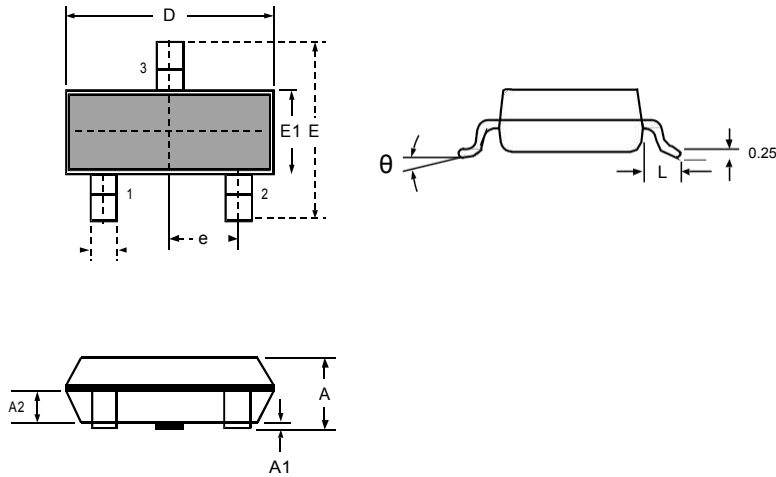

**DIMENSIONS**

SYMBOL	MILLIMETER		INCHES	
	MIN	MAX	MIN	MAX
A	0.900	1.150	0.035	0.045
A1	0.000	0.100	0.000	0.004
A2	0.900	1.050	0.035	0.041
D	2.800	3.000	0.110	0.118
b	0.300	0.500	0.012	0.020
E	2.250	2.550	0.089	0.100
E1	1.200	1.400	0.047	0.055
e	0.950 BSC		0.037 BSC	
L	0.300	0.500	0.012	0.020
θ	0	8°	0	8°

**Marking**

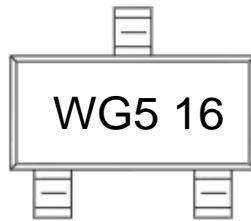

**Ordering information**

Order code	Package	Base qty	Delivery mode
PESD5V0S2BT	SOT-23	3000	Tape and reel