

BAV99

Switching Diodes

Features

- Fast Switching Speed
- For General Purpose Switching Applications.
- High Conductance

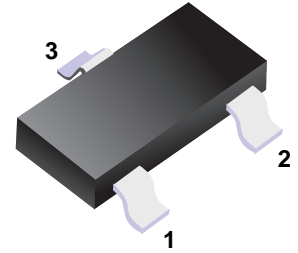

Simplified outline(SOT-23)

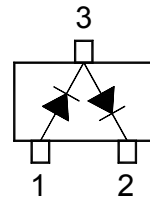

Marking

Marking	A7
---------	----

Absolute Maximum Ratings Ta = 25°C

Parameter	Symbol	Rating	Unit
Repetitive Peak Reverse Voltage	V _{RRM}	100	V
Continuous Reverse Voltage	V _R	75	
Forward Current (Double Diode Loaded)	I _F	125	mA
Forward Current (Single Diode Loaded)		215	
Repetitive Peak Forward Current	I _{FRM}	450	
Non-repetitive Peak Forward Surge Current	I _{FSM}	t=1s	0.5
		t=1ms	1
		t=1us	1.5
Power Dissipation	P _d	350	mW
Junction Temperature	T _J	150	°C
Storage Temperature range	T _{stg}	-65 to 150	

Electrical Characteristics Ta = 25°C

Parameter	Symbol	Test Conditions	Min	Typ	Max	Unit
Reverse breakdown voltage	V _R	I _R = 100 uA	100			V
Forward voltage	V _F	I _F = 1 mA			0.715	
		I _F = 10 mA			0.855	
		I _F = 50 mA			1	
		I _F = 150 mA			1.25	
Reverse voltage leakage current	I _R	V _R = 25 V			30	nA
		V _R = 75 V			1	uA
		V _R = 25 V , T _J =150°C			30	
		V _R = 75 V , T _J =150°C			50	
Junction capacitance	C _j	V _R = 0 V, f= 1 MHz			1.5	pF
Reverse recovery time	t _{rr}	I _F =I _R =10mA, I _R =1mA, R _L =100Ω			4	ns

■ Typical Characteristics

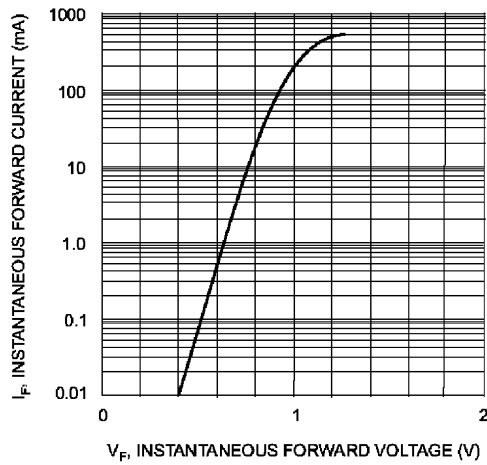

Fig. 1 Forward Characteristics

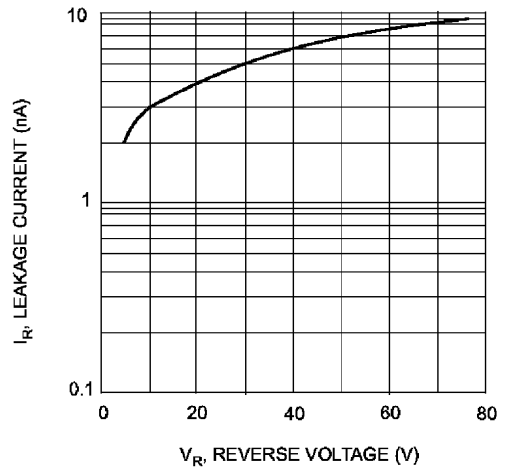

Fig. 2 Typical Leakage Current vs Reverse Voltage

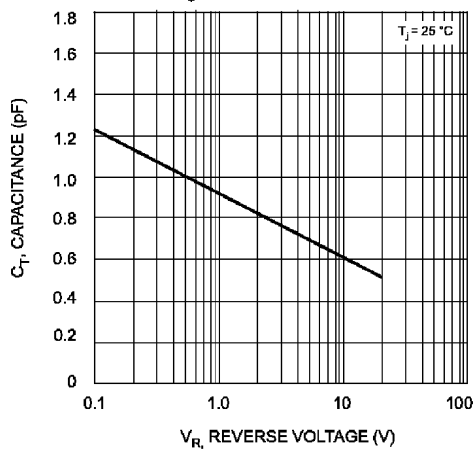
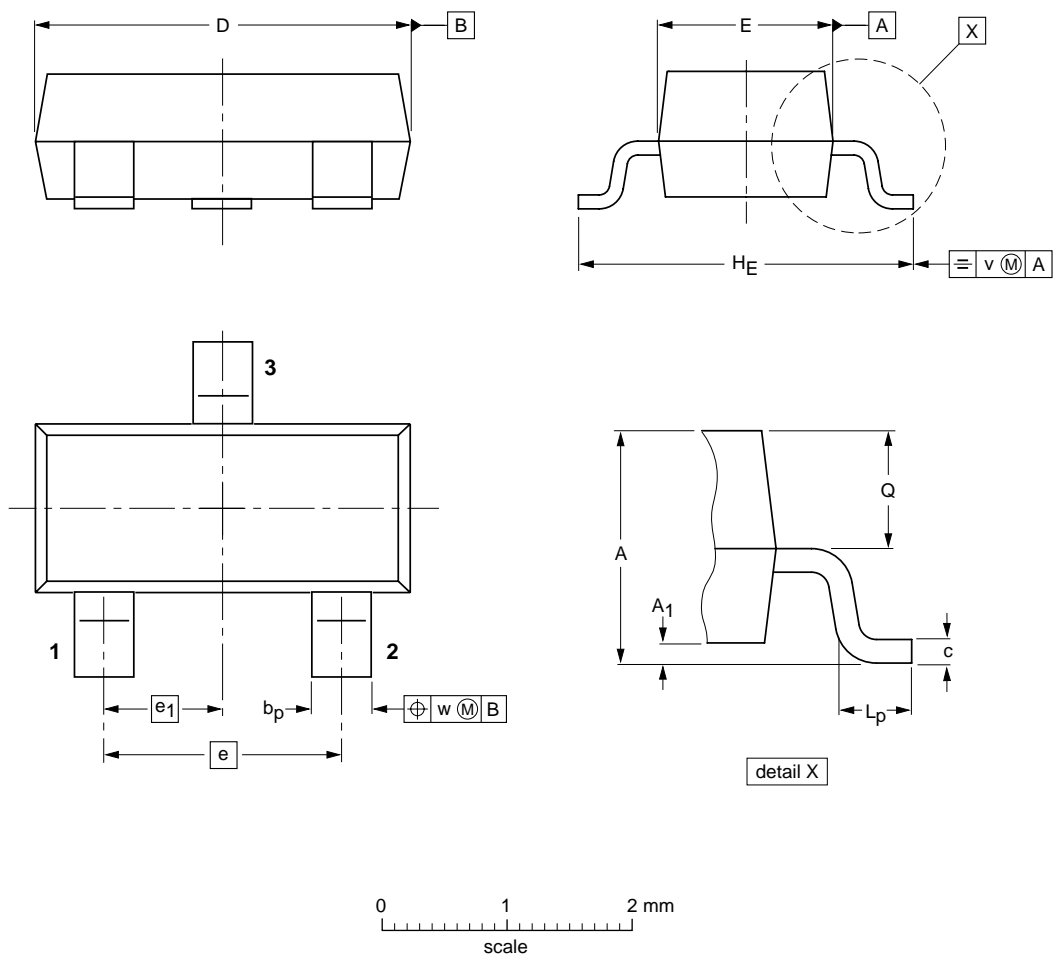

Fig. 3 Typical Total Capacitance vs Reverse Voltage

■ SOT-23



DIMENSIONS (mm are the original dimensions)

UNIT	A	A ₁ max.	b _p	c	D	E	e	e ₁	H _E	L _p	Q	v	w
mm	1.1 0.9	0.1	0.48 0.38	0.15 0.09	3.0 2.8	1.4 1.2	1.9	0.95	2.5 2.1	0.45 0.15	0.55 0.45	0.2	0.1