

Figure 7. External Clock Synchronization

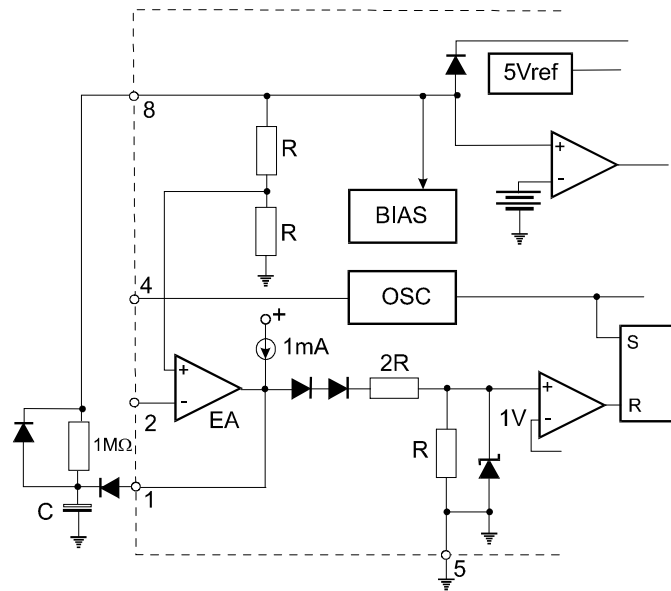

Figure 8. Soft-Start Circuit

Typical Performance Characteristics

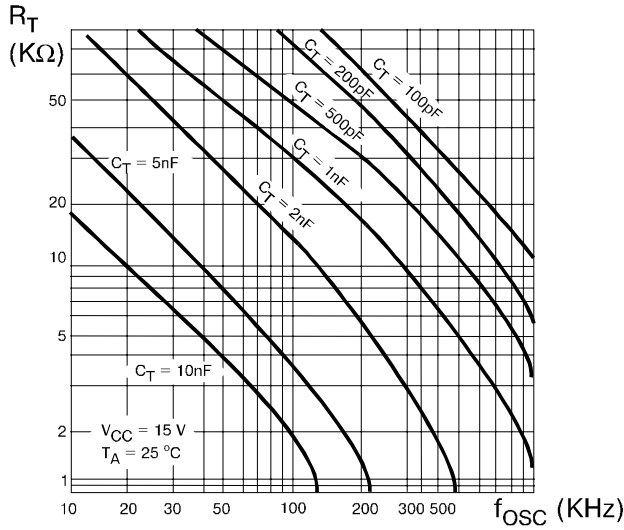

Figure 1. Timing Resistor vs. Oscillator Frequency

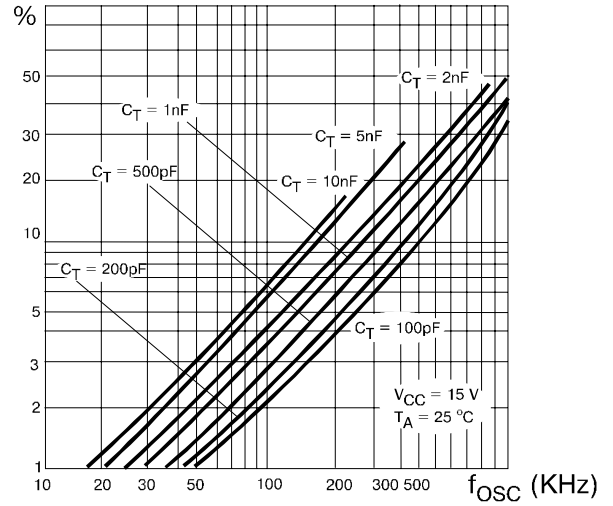

Figure 2. Output Dead-Time vs. Oscillator Frequency

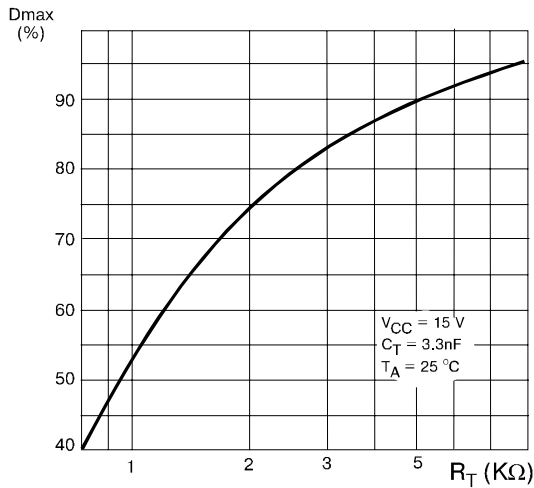

Figure 3. Maximum Output Duty Cycle vs. Timing Resistor (UC3842/43)

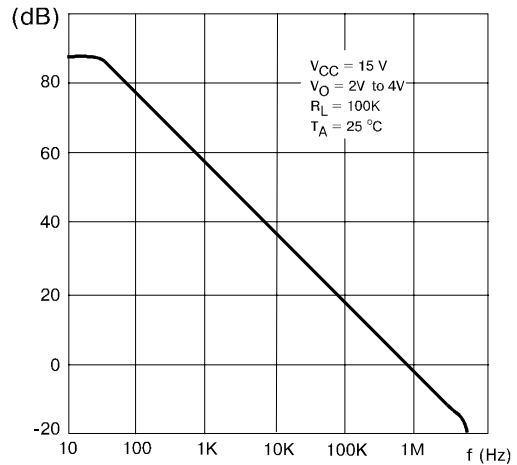

Figure 4. Error Amp Open-Loop Gain vs. Frequency

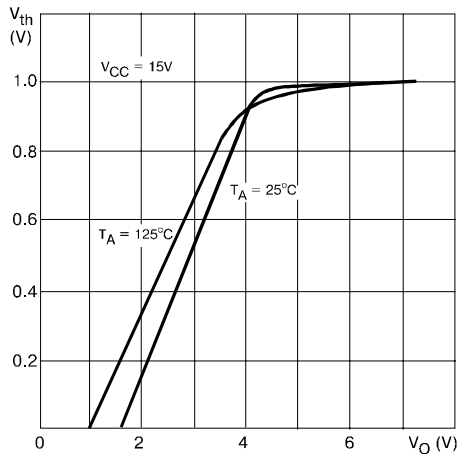

Figure 5. Current Sense Input Threshold vs. Error Amp Output Voltage

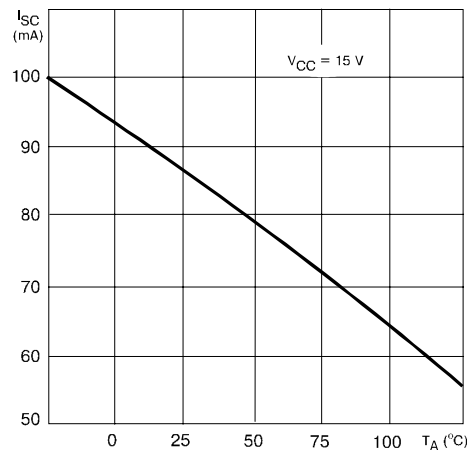

Figure 6. Reference Short Circuit Current vs. Temperature

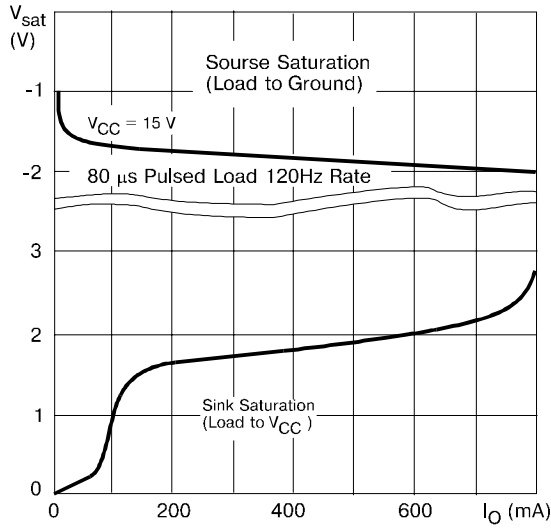

Figure 7. Output Saturation Voltage vs. Load Current
 $T_A = 25^\circ\text{C}$

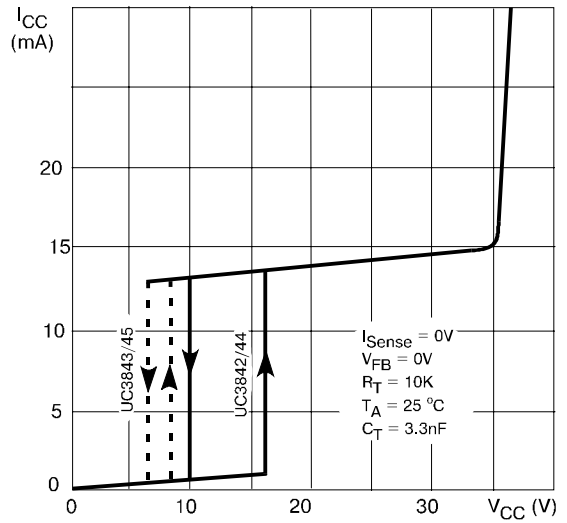

Figure 8. Supply Current vs. Supply Voltage

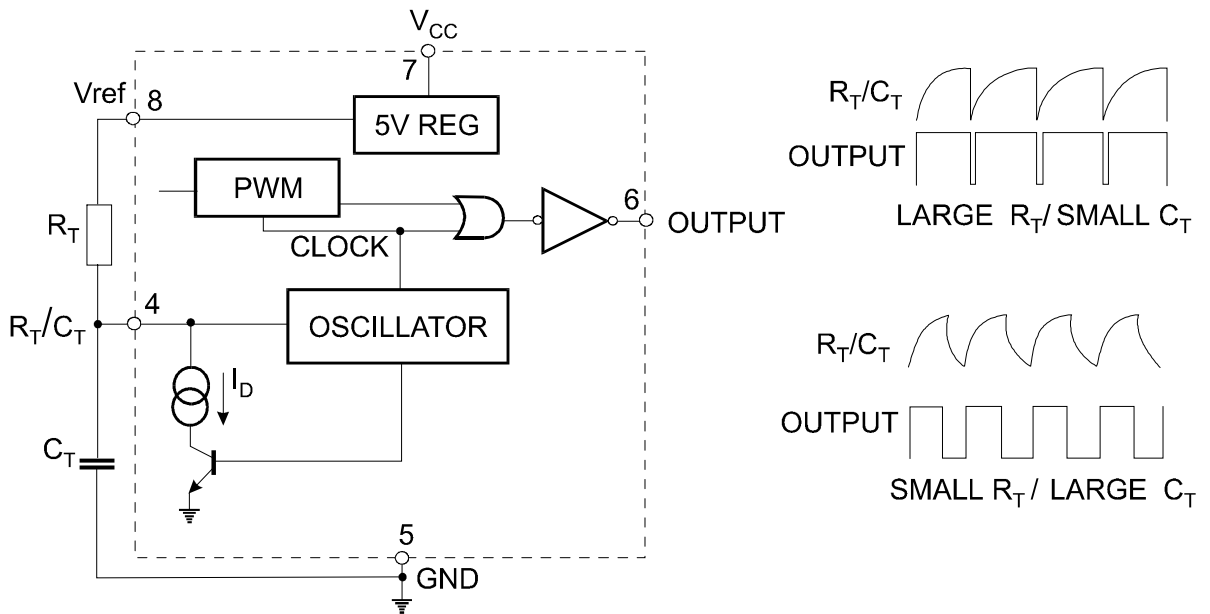

Figure 9. Oscillator and Output Waveforms

Ordering information

Order code	Package	Baseqty	Deliverymode
UC2842B	SOP-8	2500	Tape and reel
UC2843B	SOP-8	2500	Tape and reel
UC2844B	SOP-8	2500	Tape and reel
UC2845B	SOP-8	2500	Tape and reel