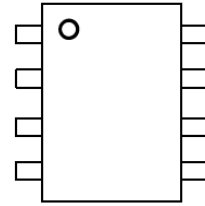

**1.1A LithiumIon Battery Linear Charger**

## Applications

- Cellular Telephones
- Mobile Power Supply
- Digital Still Cameras
- MP3 Players
- Bluetooth Applications
- Portable Devices
- USB Bus-Powered Chargers

**■ Simplified outline(ESOP-8)**

## Features

- Protection of battery cell reverse connection
- Programmable charge current up to 1.1A
- No MOSFET sense resistor or blocking diode required
- Complete linear Charger for single Cell Lithium-Ion Batteries
- CC and CV operation with thermal regulation to maximize Rate without risk of overheating
- Preset 4.2V charge voltage with  $\pm 1\%$  accuracy
- Automatic Recharge
- Two Status Indication for Charge status, no battery and battery failure indicators
- C/10 charge termination
- 55 $\mu$ A supply current in shutdown
- 2.9V trickle current charge threshold
- Soft-Start limits inrush current
- Battery Temperature Sensing
- Available in SOP-8 and ESOP-8 package

## GENERAL DESCRIPTION

TP4056 is a complete CC/CV linear charger for single cell lithium-ion batteries. it is specifically designed to work within USB power Specifications.

No external sense resistor is needed and no blocking diode is required due to the internal P-MOSFET architecture. Thermal feedback regulates the charge current to limit the die temperature during high power operation or high ambient temperature .The charge voltage is fixed at 4.2V, and the charge current can be programmed externally with a single resistor. The

TP4056 automatically terminates the charge cycle when the charge current drops to 1/10<sup>th</sup> the programmed value after the final float voltage is reached.

When the input supply (wall adapter or USB supply) is removed the TP4056 automatically enters a low current state dropping the battery drain current to less than 2 $\mu$ A. The TP4056 can be put into shutdown mode reducing the supply current to 55 $\mu$ A.

Other features include Battery temperature monitor, under-voltage lockout, automatic recharge and two status pins to indicate charge and charge termination.

## Typical Application

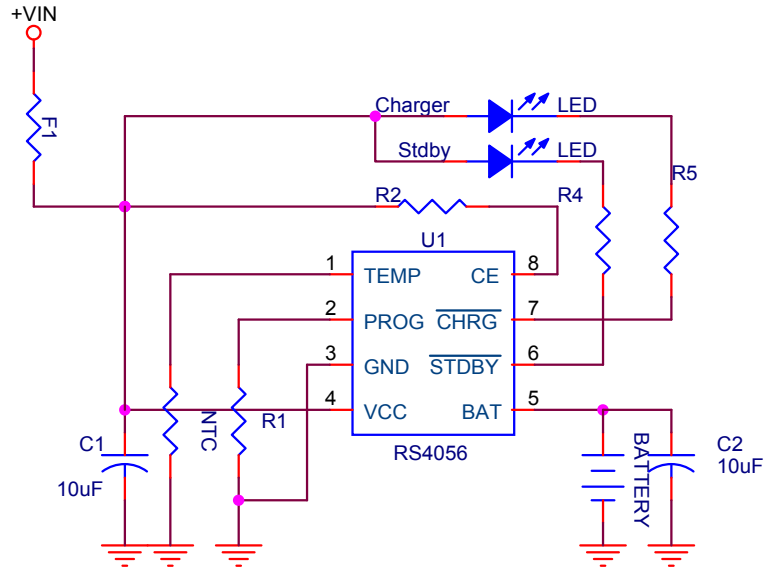

## Pin Configuration

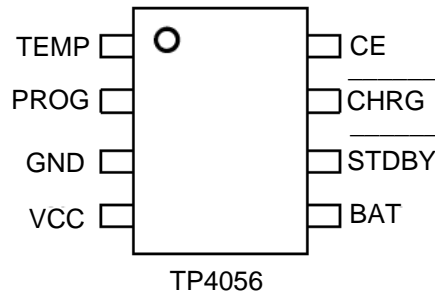

Typical charge cycle (1100 mAh Battery)

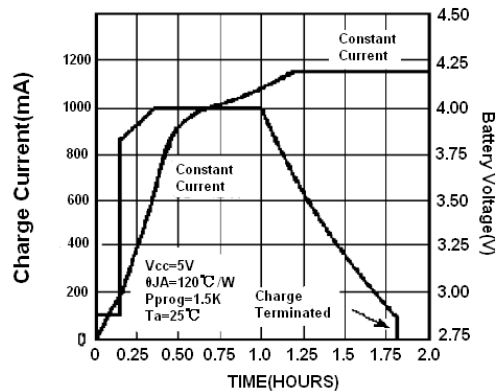

## Pin Assignment

PIN Num.	Symbol	Function
1	TEMP	<p><b>Temperature sense input</b></p> <p>Connecting TEMP pin to NTC thermistor's output in Lithium ion battery pack. If TEMP pin's voltage is below 45% or above 80% of supply voltage V<sub>CC</sub>, this means that battery's temperature is too low or too high, charging is suspended. The temperature sense function can be disabled by grounding the TEMP pin.</p>
2	PROG	<p><b>Constant Charge Current Setting and Charge Current Monitor Pin</b></p> <p>The charge current is programmed by connecting a resistor R<sub>PROG</sub> from this pin to GND. When in precharge mode, the PROG pin's voltage is regulated to 0.1V. When charging in constant-current mode this pin's voltage is regulated to 1V. In all modes during charging, the voltage on this pin can be used to measure the charge current using the following formula:</p> $I_{PROG} = \frac{V_{PROG}}{R_{PROG}} \times 1450$
3	GND	<b>Ground</b>
4	VCC	<p><b>Positive input supply voltage</b></p> <p>Provides power to the internal circuit. When V<sub>CC</sub> drops to within 80mV of the BAT pin voltage, the RS4056 enters low power sleep mode, dropping I<sub>BAT</sub> to less than 2μA.</p>
5	BAT	<p><b>Battery connection Pin</b></p> <p>Connect the positive terminal of the battery to this pin. Dropping BAT pin's current to less than 2μA when IC in disable mode or in sleep mode. BAT pin provides charge current to the battery and provides regulation voltage of 4.2V.</p>
6	$\overline{STDBY}$	<p><b>Charge terminated status output</b></p> <p><math>\overline{STDBY}</math> is pulled low by an internal switch to indicate a battery charge terminated; this means Charge termination. Otherwise pin is in high impedance state.</p>
7	$\overline{CHRG}$	<p><b>Open-Drain charge status output</b></p> <p>When the battery is being charged, the <math>\overline{CHRG}</math> pin is pulled low by an internal switch, otherwise, <math>\overline{CHRG}</math> pin is in high impedance state.</p>
8	CE	<p><b>Chip enable input</b></p> <p>A high input will put the device in the normal operating mode. Pulling the CE pin to low level will put the TP4056 into disable mode. The CE pin can be driven by TTL or CMOS logic level.</p>

## Block Diagram

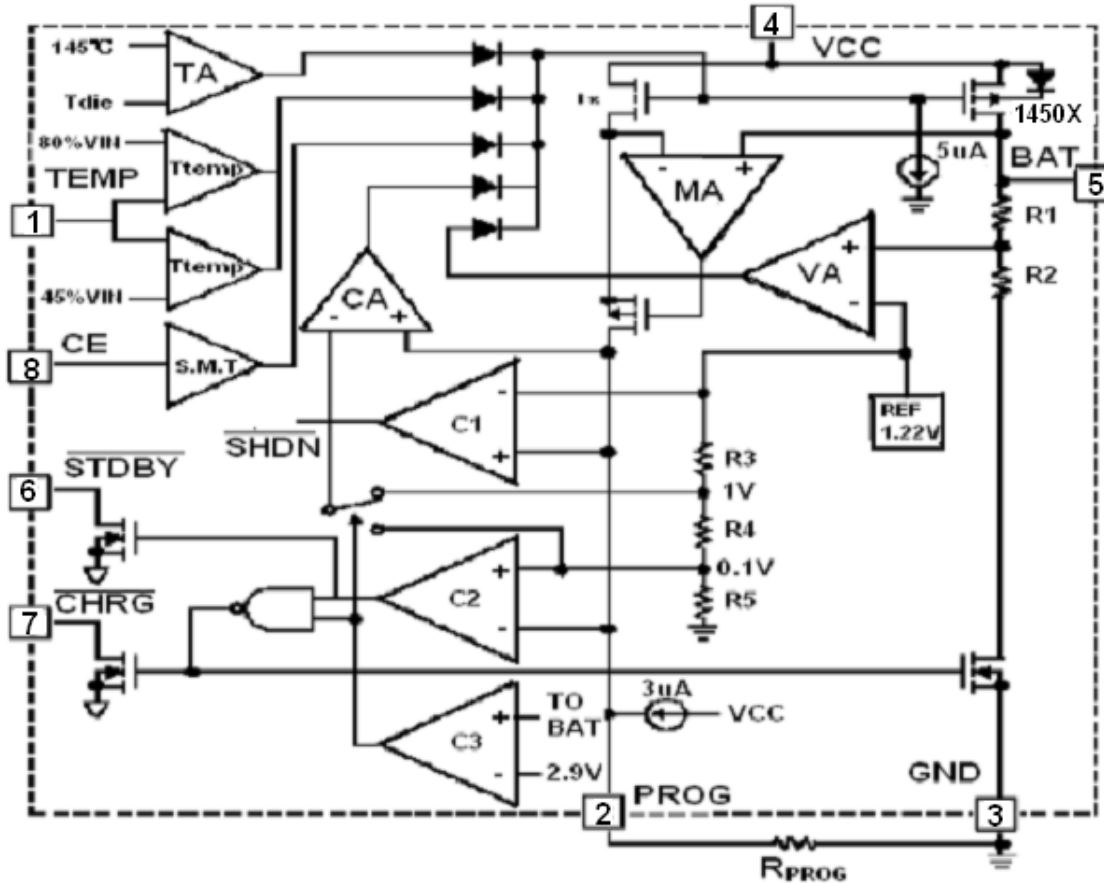

## Absolute Maximum Ratings

Parameter	Rating	Unit
Input supply voltage : Vcc	-0.3~8	V
PROG pin voltage	-0.3~VCC+0.3	V
BAT pin voltage	-0.3~7	V
TEMP pin voltage	-0.3~10	V
CHRG pin voltage	-0.3~10	V
STDBY pin voltage	-0.3~10	V
CE pin voltage	-0.3~10	V
BAT pin current	1200	mA
PROG pin current	1200	uA
Maximum junction temperature	150	°C
Operating ambient temperature	-40~85	°C
Storage temperature	-65~125	°C
Soldering temperature and time	+260 (Recommended 10S)	°C

Caution: The absolute maximum ratings are rated values exceeding which the product could suffer physical damage. These values must therefore not be exceeded under any conditions.

## Electrical Characteristics

Symbol	Parameter	Test Condition	MAX	TPY	MIN	Unit
V <sub>CC</sub>	Input supply voltage		4.0	5.0	8.0	V
I <sub>CC</sub> -I <sub>BAT</sub>	Static Current	Charge mode, R <sub>PROG</sub> =1.3K		150	500	uA
		Standby mode (charge end)		55	100	uA
		Shutdown mode R <sub>PROG</sub> not connected, V <sub>CC</sub> <V <sub>BAT</sub> ,or V <sub>CC</sub> <V <sub>UV</sub> )		55	100	uA
V <sub>FLOAL</sub>	Regulated output voltage	0°C≤T <sub>A</sub> ≤85°C I <sub>BAT</sub> =40mA	4.158	4.2	4.242	V
I <sub>BAT</sub>	BAT pin current (The condition of current mode is V <sub>BAT</sub> =3.9V)	R <sub>PROG</sub> =2.6K, current mode	525	550	575	mA
		R <sub>PROG</sub> =1.3K,current mode	1050	1100	1150	mA
		Standby mode: V <sub>BAT</sub> =4.2V	0	-2.5	-6.0	uA
		Shutdown mode, R <sub>PROG</sub> not connected		±1	±2	uA
		Sleep mode, V <sub>CC</sub> =0V		-1	-2	uA
I <sub>TRIKL</sub>	Trickle charge current	V <sub>BAT</sub> <V <sub>TRIKL</sub> , R <sub>PROG</sub> =1.3K	120	130	140	mA
V <sub>TRIKL</sub>	Trickle charge threshold voltage	R <sub>PROG</sub> =1.3K, V <sub>BAT</sub> rising	2.8	2.9	3.0	V
V <sub>TRHYS</sub>	Trickle voltage hysteresis voltage	R <sub>PROG</sub> =1.3K	150	200	250	mV
V <sub>UV</sub>	V <sub>CC</sub> under voltage lockout threshold	V <sub>CC</sub> from low to high	3.5	3.7	3.9	V
V <sub>UVHYS</sub>	V <sub>CC</sub> under voltage lockout hysteresis		150	200	300	mV
V <sub>ASD</sub>	V <sub>CC</sub> -V <sub>BAT</sub> lockout threshold voltage	V <sub>CC</sub> from low to high	100	140	180	mV
		V <sub>CC</sub> from high to low	50	80	110	mV
I <sub>TERM</sub>	C/10 termination current threshold	R <sub>PROG</sub> =2.6K	60	70	80	mA
		R <sub>PROG</sub> =1.3K	120	130	140	mA
V <sub>PROG</sub>	PROG pin voltage	R <sub>PROG</sub> =1.3K, current mode	0.9	1.0	1.1	V
V <sub>CHRG</sub>	$\overline{CHRG}$ Pin output low voltage	$I_{\overline{CHRG}} = 5mA$		0.3	0.6	V
V <sub>STDBY</sub>	$\overline{STDBY}$ Pin output low voltage	$I_{\overline{STDBY}} = 5mA$		0.3	0.6	V

$T_{TEMP-H}$	The voltage at TEMP increase			80	83	%VCC
$T_{TEMP-L}$	The voltage at TEMP decrease		42	45		%VCC
$\Delta V_{RECHARGE}$	Recharge battery threshold voltage	$V_{FLOAT} - V_{RECHRG}$	120	180	240	mV
$T_{LIM}$	Thermal protection temperature			145		°C
$R_{DS(ON)}$	The resistance of power FET "ON" (between VCC and BAT)			650		mΩ
$T_{SS}$	Soft-start time	$I_{BAT}=0$ to $I_{BAT}=1300V/R_{PROG}$		20		uS
$T_{RECHARGE}$	Recharge comparator filter time	$V_{BAT}$ from high to low	0.8	1.8	4	mS
$T_{TEMP}$	Termination comparator filter time	$I_{BAT}$ below $I_{CHG}/10$	0.8	1.8	4	mS
$I_{PROG}$	PROG pin pull-up current			2.0		uA

## Description of the Principle

The TP4056 is a complete CC/CV linear charge for single cell lithium-ion batteries. CC/CV to charger batter by internal MOSFET .It can deliver up to 1.1A of charge current .No blocking diode or external current sense resistor is required. TP4056 include two Open-Drain charge status Pins: Charge status indicator  $\overline{CHRG}$  and battery failure status output  $\overline{STDBY}$  .

The internal thermal regulation circuit reduces the programmed charge current if the die temperature attempts to rise above a preset value of approximately 145 °C . This feature protects the TP4056 from excessive temperature, and allows the user to push the limits of the power handling capability of a given circuit board without risk of damaging the TP4056 or the external components. Another benefit of adopting thermal regulation is that charge current can be set according to typical, not worst-case, ambient temperatures for a given application with the assurance that the charger will automatically reduce the current in worst-case conditions.

The charge cycle begins when the voltage at the V<sub>CC</sub> pin rises above the UVLO level, a current set resistor is connected from the PROG pin to ground, and the CE pin is pulled above the chip enable threshold. The  $\overline{CHRG}$  pin outputs a logic low to indicate that the charge cycle is on going. At the beginning of the charge cycle, if the battery voltage is below 2.9V, the charge is in precharge mode to bring the cell voltage up to a safe level for charging. The charger goes into the fast charge CC mode once the voltage on the BAT pin rises above 2.9 V. In CC mode, the charge current is set by R<sub>PROG</sub>. When the battery approaches the regulation voltage 4.2V, the charge current begins to decrease as the TP4056 enters the CV mode. When the current drops to charge termination threshold, the charge cycle is terminated, and  $\overline{CHRG}$  pin assumes a high impedance state to indicate that the charge cycle is terminated and  $\overline{STDBY}$  pin is pulled low. The charge termination threshold is 10% of the current in CC mode. To restart the charge cycle, remove the input voltage and reapply it, or momentarily force CE pin to 0V. The charge cycle can also be automatically restarted if the BAT pin voltage falls below the recharge threshold. The on-chip reference voltage, error amplifier and the resistor divider provide regulation voltage with 1% accuracy which can meet the requirement of lithium-ion and lithium polymer batteries. When the input voltage is not present, or input voltage is below V<sub>BAT</sub>, the charger goes into a sleep mode, dropping battery drain current to less than 3 μA. This greatly reduces the current drain on the battery and increases the standby time. The charger can be shutdown by forcing the CE pin to GND.

The charging profile is shown in the following figure:

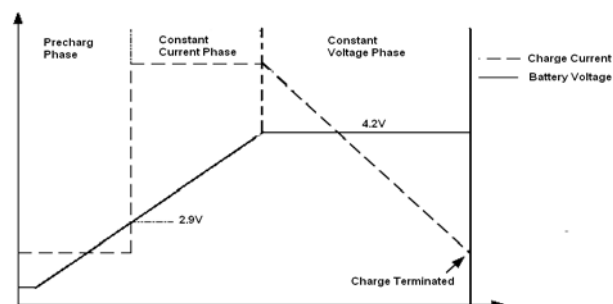

## Programming Charge Current

The charge current is programmed using a single resistor from the PROG pin to ground. The program resistor and the charge current are calculated using the following equations.

$$R_{PROG} = \frac{1450}{I_{BAT}};$$

In application, according the charge current to determine  $R_{PROG}$ , the relation between  $R_{PROG}$  and charge current can reference the following chart:

$R_{PROG}$ (K)	$I_{BAT}$ (mA)
24K	60
12K	120
6K	240
4K	363
3K	483
2K	725
1.3K	1115

## Charge Termination

A charge cycle is terminated when the charge current falls to 1/10<sup>th</sup> the programmed value after the final float voltage is reached. This condition is detected by using an internal filtered comparator to monitor the PROG pin. When the PROG pin voltage falls below 100mV for longer than  $t_{TEMP}$  (typically 1.8mS), Charging is terminated. The charge current is latched off and the TP4056 enters standby mode, where the input supply current drops to 55  $\mu$ A (**Note:C/10 termination is disabled in trickle charging and thermal limiting modes**).

When charging, transient loads on the BAT pin can cause the PROG pin to fall below 100mV for short periods of time before the DC charge current has dropped to 1/10<sup>th</sup> the programmed value. The 1.8mS filter time ( $t_{TEMP}$ ) on the termination comparator ensures that transient loads of this nature do not result in premature charge cycle termination. Once the average charge current drops below 1/10<sup>th</sup> the programmed value, the TP4056 terminated the charge cycle and ceases to provide any current through the BAT pin. In this state all loads on the BAT pin must be supplied by the battery.

The TP4056 constantly monitors the BAT pin voltage in standby mode. If this voltage drops below the 4.10V recharge threshold ( $V_{RECHRG}$ ), another charge cycle begins and current is once again supplied to the battery. To manually restart a charge cycle when in standby mode, the input voltage must be removed and reapplied or the charger must be shut down and restarted using the PROG pin. Figure 1 shows the state diagram of a typical charge cycle



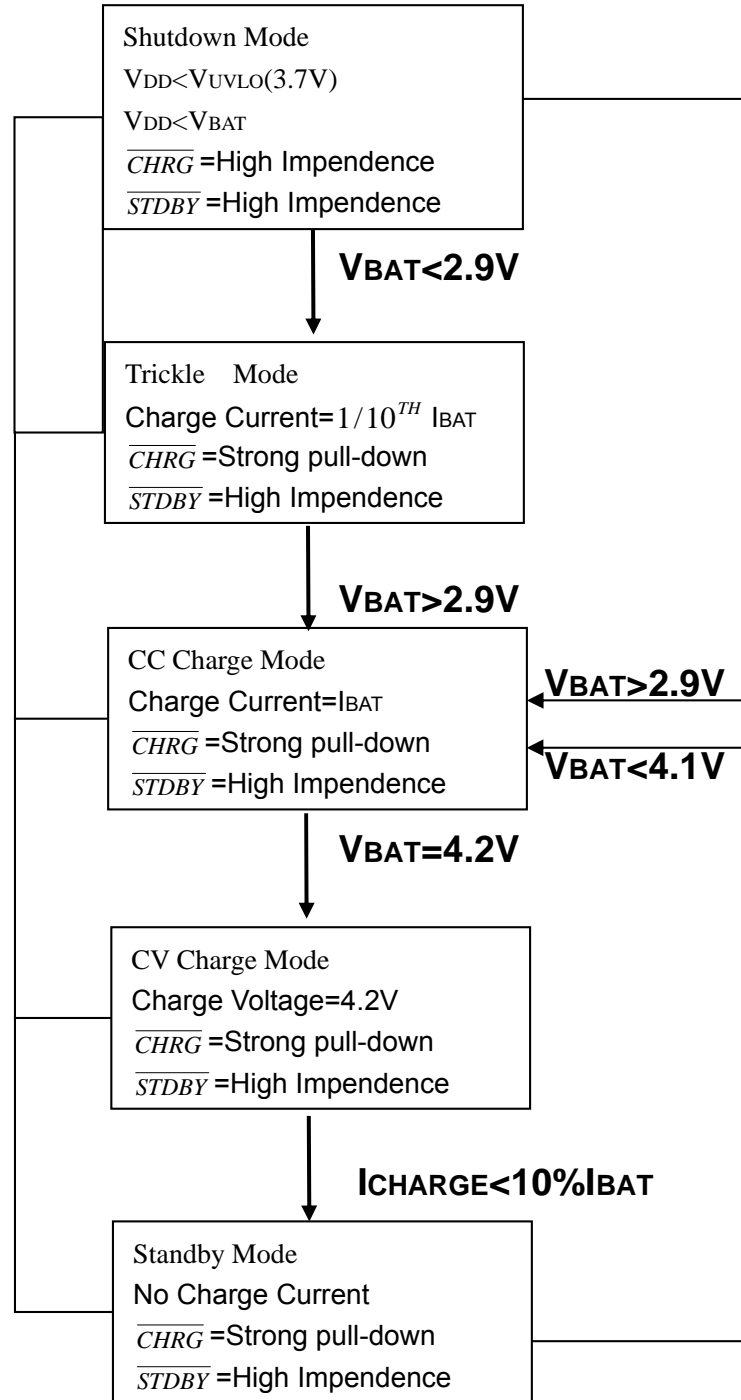

**Fig.1 State diagram of a typical charge cycle**

## Charge status indicator

TP4056 has two open-drain status indicator output  $\overline{CHRG}$  and  $\overline{STDBY}$ .  $\overline{CHRG}$  is pull-down when the TP4056 in a charge cycle. In other status  $\overline{CHRG}$  in high impedance,  $\overline{CHRG}$  and  $\overline{STDBY}$  are all in high impedance when the battery out of the normal temperature.

Represent in failure state, when TEMP pin in typical connecting, or the charger with no battery: red LED and green LED all don't light. The battery temperature sense function is disabled by connecting TEMP pin to GND. If battery is not connected to charger,  $\overline{CHRG}$  pin outputs a PWM level to indicate no battery. If BAT pin connects a 10  $\mu$ F capacitor, the frequency of  $\overline{CHRG}$  flicker about 1-4S, If not use status indicator should set status indicator output connected to GND.

Charger's Status	Red led $\overline{CHRG}$	Green led $\overline{STDBY}$
Charging	light	dark
Battery in full state	dark	light
Under-voltage, battery's temperature is too high or too low, or not connect to battery(use TEMP)	dark	dark
BAT pin is connected to 10uF capacitor. No battery mode (TEMP=GND)	Green LED bright, Red LED flicker F=1-4 S	

## Thermal limiting

An internal thermal feedback loop reduces the programmed charge current if the die temperature attempts to rise above a preset value of approximately 145 °C. The feature protects the TP4056 from excessive temperature and allows the user to push the limits of the power handling capability of a given circuit board without risk of damaging the TP4056. The charge current can be set according to typical (not worst-case) ambient temperature with the assurance that the charger will automatically reduce the current in worst-case conditions.

To prevent the damage caused by the very high or very low temperature done to the battery pack, the TP4056 continuously senses battery pack temperature by measuring the voltage at TEMP pin determined by the voltage divider circuit and the battery's internal NTC thermistor as shown in Figure 1.

The TP4056 compares the voltage at TEMP pin ( $V_{TEMP}$ ) against its internal  $V_{LOW}$  and  $V_{HIGH}$  thresholds to determine if charging is allowed. In TP4056,  $V_{LOW}$  is fixed at (45% $\times V_{CC}$ ), while  $V_{HIGH}$  is fixed at (80% $\times V_{CC}$ ). If  $V_{TEMP} < V_{LOW}$  or  $V_{TEMP} > V_{HIGH}$ , it indicates that the battery temperature is too high or too low and the charge cycle is suspended. When  $V_{TEMP}$  is between  $V_{LOW}$  and  $V_{HIGH}$ , charge cycle resumes. The battery temperature sense function can be disabled by connecting TEMP pin to GND.

## Selecting R1 and R2

The values of R1 and R2 in the application circuit can be determined according to the assumed temperature monitor range and thermistor's values. The Follows is an example: Assume temperature monitor range is  $T_L \sim T_H$ , ( $T_L < T_H$ ); the thermistor in battery has negative temperature coefficient (NTC),  $R_{TL}$  is thermistor's resistance at  $T_L$ ,  $R_{TH}$  is the resistance at

TH. so  $R_{TL} > R_{TH}$ , then at temperature  $T_L$ , the voltage at TEMP pin is:

$$V_{TEMPH} = \frac{R_2 // R_{TH}}{R_1 + R_2 // R_{TH}} \times V_{IN}$$

At temperature  $T_H$ , the voltage at TEMP pin is:

$$V_{TEMPL} = \frac{R_2 // R_{TL}}{R_1 + R_2 // R_{TL}} \times V_{IN}$$

We know  $V_{TEMPL} = V_{HIGH} = K_2 \times V_{CC}$  ( $K_2=0.8$ );  $V_{TEMPH} = V_{LOW} = K_1 \times V_{CC}$  ( $K_1=0.45$ ) Then we can have:

$$R_1 = \frac{R_{TL} \times R_{TH} (K_2 - K_1)}{(R_{TL} - R_{TH}) K_2 \times K_1}; \quad R_1 = \frac{R_{TL} \times R_{TH} (K_2 - K_1)}{R_{TL} (K_1 - K_1 \times K_2) - R_{TH} (K_2 - K_1 \times K_2)}$$

Likewise, for positive temperature coefficient thermistor in battery, we have  $R_{TH} > R_{TL}$  and we can calculate:

$$R_1 = \frac{R_{TL} \times R_{TH} (K_2 - K_1)}{(R_{TH} - R_{TL}) K_2 \times K_1}; \quad R_1 = \frac{R_{TL} \times R_{TH} (K_2 - K_1)}{R_{TH} (K_1 - K_1 \times K_2) - R_{TL} (K_2 - K_1 \times K_2)}$$

We can conclude that temperature monitor range is independent of power supply voltage  $V_{CC}$  and it only depends on  $R_1$ ,  $R_2$ ,  $R_{TL}$  and  $R_{TH}$ : The values of  $R_{TH}$  and  $R_{TL}$  can be found in related battery handbook or deduced from testing data. In actual application, if only one terminal temperature is concerned (normally protecting overheating), there is no need to use  $R_2$  but  $R_1$ . It becomes very simple to calculate  $R_1$  in this case.

## Under Voltage lockout (UVLO)

An internal under voltage lockout circuit monitors the input voltage and keeps the charger in shutdown mode until  $V_{CC}$  rises above the under voltage lockout threshold. If the UVLO comparator is tripped, the charger will not come out of shutdown mode until  $V_{CC}$  rises 140mV above the battery voltage.

## Manual terminate

At any time of the cycle of charging will put the TP4056 into disable mode to pull CE pin to GND, or remove  $R_{PROG}$  (PROG pin is float). This made the battery drain current to less than 2 $\mu$ A and reducing the supply current to 55 $\mu$ A. To restart the charge cycle, set CE pin in high level or connect a programming resistor.

If TP4056 in the under voltage Lockout mode, the  $\overline{CHRG}$  and  $\overline{STDBY}$  are all in high impedance state, or  $V_{CC}$  is above BAT pin 140mV, or  $V_{CC}$  is too low.

## Auto restart

Once charge is been terminated, TP4056 immediately use a 1.8ms filter time ( $t_{RECHARGE}$ ) on the termination comparator to constant monitor the voltage on BAT pin. If this voltage drops below the 4.1V recharge threshold (about between 80% and 90% of  $V_{CC}$ ), another charge cycle begins. This ensured the battery maintained (or approach) to a charge full status and

avoid the requirement of restarting the periodic charging cycle. In the recharge cycle,  $\overline{CHRG}$  pin enters a pulled down status.

### Stability Considerations

In CC mode, the PROG pin is in the feedback loop, not the battery. The CC mode stability is affected by the impedance at the PROG pin. With no additional capacitance on the PROG pin, the charger is stable with program resistor values as high as 20K. However, additional capacitance on this node reduces the maximum allowed program resistor. Therefore, if I<sub>PROG</sub> pin is loaded with a capacitance C, the following equation should be used to calculate the maximum resistance value for R<sub>PROG</sub>:

$$R_{PROG} \leq \frac{1}{2\pi \times 10^5 \times C_{PROG}}$$

As user, may think charge current is important, not instantaneous current. For example, to run a low current mode switch power which parallel connected with battery, the average current from BAT pin usually importance to instantaneous current. In this case, In order to measure average charge current or isolate capacitive load from I<sub>PROG</sub> pin, a simple RC filter can be used on PROG pin as shown in Figure 2. In order to ensure the stability add a 10K resistor between PROG pin and filter capacitor.

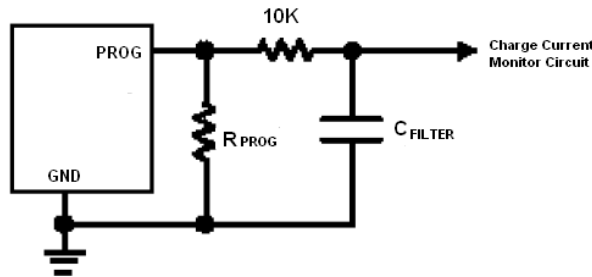

**Fig.2 Isolating with capacitive load on PROG Pin**

### Power Dissipation

The conditions that cause the TP4056 to reduce charge current through thermal feedback can be approximated by considering the power dissipated in the IC. Nearly all of this power dissipation is generated by the internal MOSFET-this is calculated to be approximately:

$P_D = (V_{CC} - V_{BAT}) \times I_{BAT}$  The approximate ambient temperature at which the thermal feedback begins to protect the IC is:

$$T_A = 145^\circ C - P_D \times \theta_{JA}; \quad \text{So: } T_A = 145^\circ C - (V_{CC} - V_{BAT}) \times I_{BAT} \times \theta_{JA}$$

For example: The TP4056 with 5V supply voltage through programmable provides full limiting current 850mA to a charge lithium-ion battery with 3.85V voltage. If  $\theta_{JA}$  is 100 °C/W ( reference to PCB layout considerations), When TP4056 begins to decrease the charge current, the ambient temperature about:

$$T_A = 145 - (5 - 3.85) \times 0.85 \times 100 = 47.25^\circ\text{C}$$

TP4056 can work in the condition of the temperature is above 47.25°C, but the charge current will pull down to below 850mA. In a fixed ambient temperature, the charge current is calculated to be approximately:

$$I_{BAT} = \frac{145^\circ\text{C} - T_A}{(V_{CC} - V_{BAT}) \times \theta_{JA}}$$

Just as Description of the Principle part talks about so, the current on PROG pin will reduce in proportion to the reduced charge current through thermal feedback. In TP4056 design applications don't need to considerate the worst case of thermal condition, this point is importance, because if the junction temperature up to 145°C TP4056 will auto reduce the power dissipation.

## Thermal Considerations

Because of the small size of the thin SOP-8 or ESOP-8 package, it is important to use a good thermal PC board layout to maximize the available charge current. The PC board copper is the heat sink. The footprint copper pads should be as wide as possible and expand out to larger copper areas to spread and dissipate the heat to the surrounding ambient. Other heat sources on the board, not related to the charger, must also be considered when designing a PC board layout because they will affect overall temperature rise and the maximum charge current.

## Add thermal regulation current

It will effective to decrease the power dissipation through reduce the voltage of both ends of the inner MOSFET. In the thermal regulation, this action of transporting current to battery will raise. One of the measure is through an external component(as a resistor or diode) to consume some power dissipation.

For example: The TP4056 with 5V supply voltage through programmable provides full limiting current 1000mA to a charge lithium-ion battery with 3.8V voltage. If  $\theta_{JA}$  is 120°C/W, so that at 25°C ambient temperature, the charge current is calculated to be approximately:

$$I_{BAT} = \frac{145^\circ\text{C} - 25^\circ\text{C}}{(V_{CC} - I_{BAT} \times R_{CC} - V_{BAT}) \times \theta_{JA}}$$

In order to increase the thermal regulation charge current, can decrease the power dissipation of the IC through reducing the voltage (as show fig.3) of both two ends of the resistor which connecting in series with a 5V AC adapter. With square equation to calculate  $I_{BAT}$ :

$$I_{BAT} = \frac{V_{CC} - V_{BAT} - \sqrt{(V_{CC} - V_{BAT})^2 - \frac{4R_{CC} \times (145^\circ\text{C} - T_A)}{\theta_{JA}}}}{2R_{CC}}$$

If  $R_{CC}=0.25\Omega$ ,  $V_{CC}=5\text{V}$ ,  $V_{BAT}=3.75\text{V}$ ,  $T_A=25^\circ\text{C}$  and  $\theta_{JA}=120^\circ\text{C/W}$ , we can calculate the thermal

regulation charge current:  $I_{BAT} = 1080\text{mA}$ . It means that in this structure it can output 1000mA full limiting charge current at more high ambient temperature environment.

Although it can transport more energy and reduce the charge time in this application, but actually spread charge time, if STP4056 stay in under-voltage state, when  $V_{CC}$  becomes too low in voltage mode. Fig.4 shows how the voltage reduced with increase  $R_{CC}$  value in this circuit. This technique will act the best function when in order to maintain the minimize the dimension of the components and avoid voltage decreased to minimize  $R_{CC}$ .

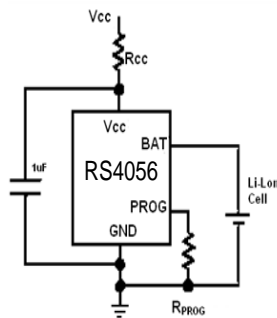

Fig.3 A Circuit To Maximum The Thermal Regulation Charge Current

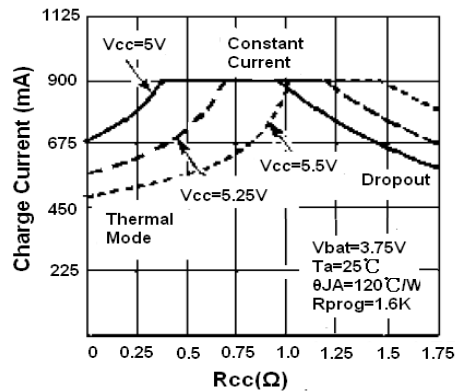

Fig.4 The Relationship Curve Between Charge Current With  $R_{CC}$

## VCC bypass capacitor

Many types of capacitors can be used for input bypassing, however, caution must be exercised when using multilayer ceramic capacitors. Because of the self-resonant and high Q characteristics of some types of ceramic capacitors, high voltage transients can be generated under some start-up conditions, such as connecting the charger input to a live power source. Adding a  $1.5\Omega$  resistor in series with a ceramic capacitor will minimize start-up voltage transients.

## Charging Current Soft Start

TP4056 includes a soft start circuit which used to maximize to reduce the surge current in the begging of charge cycle. When restart a new charge cycle, the charging current ramps up from 0 to the full charging current within  $20\mu\text{s}$ . In the start process it can maximize to reduce the action which caused by surge current load.

## USB and Wall Adapter Power

TP4056 allows charging from a USB port, a wall adapter can also be used to charge Li-Ion/Li-polymer batteries. Figure 5 shows an example of how to combine wall adapter and USB power inputs. A P-channel MOSFET, Q1, is used to prevent back conducting into the USB port when a wall adapter is present and Schottky diode, D1, is used to prevent USB power loss through the  $1K\Omega$  pull-down resistor.

Generally, AC adaptor is able to provide bigger much current than the value of specific current limiting which is 500mA for USB port. So can rise charge current to 600mA with using a N-MOSFET (Q1) and an additional set resistor value as high as 10K.

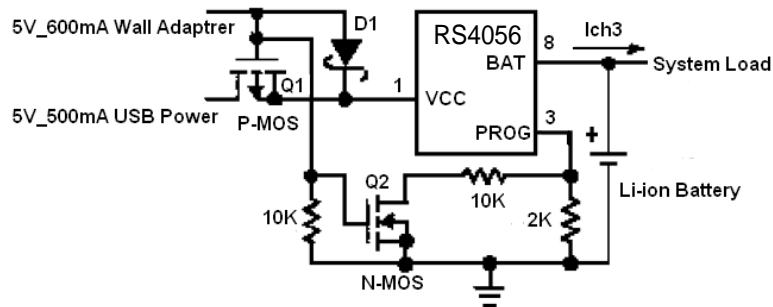

**Fig.5:Combining Wall Adapter and USB Power**

## Board Layout Considerations

$R_{PROG}$  at PROG pin should be as close to TP4056 as possible, also the parasitic capacitance at PROG pin should be kept as small as possible.

The capacitance at VCC pin and BAT pin should be as close to TP4056 as possible.

During charging, TP4056's temperature may be high, the NTC thermistor should be placed far enough to TP4056 so that the thermistor can reflect the battery's temperature correctly.

It is very important to use a good thermal PC board layout to maximize charging current. The thermal path for the heat generated by the IC is from the die to the copper lead frame through the package lead (especially the ground lead) to the PC board copper, the PC board copper is the heat sink. The footprint copper pads should be as wide as possible and expand out to larger copper areas to spread and dissipate the heat to the surrounding ambient. Feed through vias to inner or backside copper layers are also useful in improving the overall thermal performance of the charger. Other heat sources on the board, not related to the charger, must also be considered when designing a PC board layout because they will affect overall temperature rise and the maximum charge current.

The ability to deliver maximum charge current under all conditions require that the exposed metal pad on the back side of the TP4056 package be soldered to the PC board ground. Failure to make the thermal contact between the exposed pad on the backside of the package and the copper board will result in larger thermal resistance.

**ESOP-8**

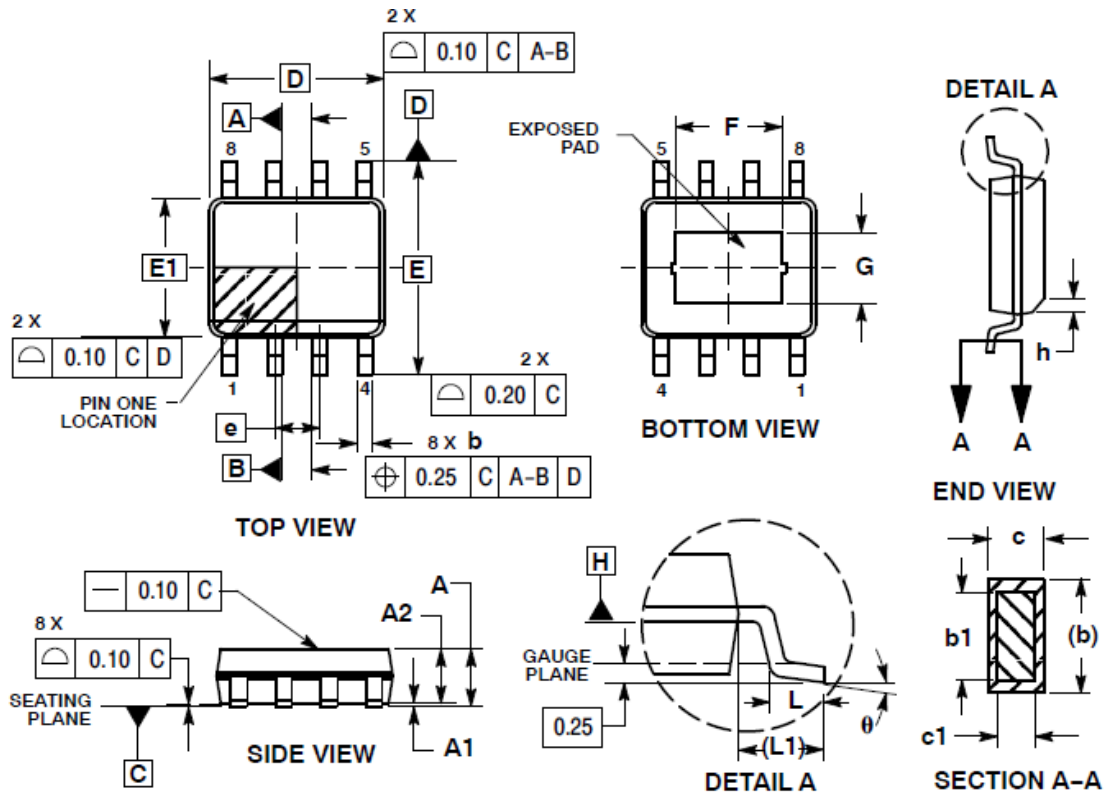

**SOLDERING FOOTPRINT**

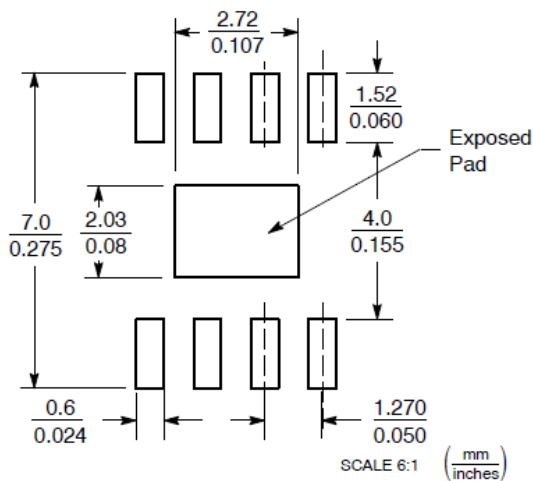

DIM	MILLIMETERS	
	MIN	MAX
A	1.35	1.75
A1	0.00	0.10
A2	1.35	1.65
b	0.31	0.51
b1	0.28	0.48
c	0.17	0.25
c1	0.17	0.23
D	4.90 BSC	
E	6.00 BSC	
E1	3.90 BSC	
e	1.27 BSC	
L	0.40	1.27
L1	1.04 REF	
F	2.24	3.20
G	1.55	2.51
h	0.25	0.50
$\theta$	0°	8°