

Product features and main applications:

NPNP five-layer structure of silicon bidirectional devices; with independent intellectual property rights of single-sided digging technology, table glass passivation process; multi-layer metallized electrodes on the back; with high blocking voltage and high temperature stability.

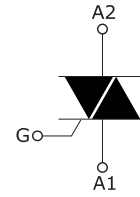

Mainly used in:

vacuum cleaners, power tools and other motor speed controllers; solid state relays; heating controllers (temperature regulation); other phase control circuits.

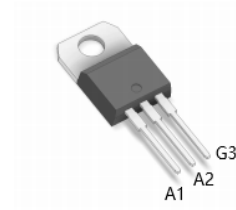

TO-220A

Characteristics

Table 1. Absolute maximum ratings (Tj = 25 ° C unless otherwise stated)

Symbol	Parameter name		value	Unit
$I_{T(RMS)}$	RMS on-state current (full sine wave)	BTA Tc=80°C	12	A
I_{TSM}	Non repetitive surge peak on-state current (full cycle, Tj initial = 25 ° C)	F=50HZ tp=20ms	120	A
I^2t	I2t value for fusing	tp=10ms	72	A ² S
di/dt	Critical rate of rise of on-state current IG = 2 x IGT, tr ≤ 100 ns	Tj=125	50	A/us

V_{DRM}/V_{RRM}	Off state repetitive peak voltage Reverse repetitive peak voltage	$T_j=25^\circ\text{C}$		600/800	V
I_{GM}	Peak gate current	$t_p=20\mu\text{s}$	$T_j=150^\circ\text{C}$	4	A
$P_{G(AV)}$	Average gate power dissipation		$T_j=150^\circ\text{C}$	1	W
T_{stg} T_j	Storage junction temperature range Operating junction temperature range			-40 to+150 -40 to+125	$^\circ\text{C}$

Table 2. Electrical characteristics ($T_j = 25^\circ\text{C}$, unless otherwise specified) --3 quadrants

Symbol	Name and test conditions	Quadrant	Range	value				Unit
I_{GT}	$V_D=12\text{V}$ $R_L=100\Omega$	I II III	MAX	BW	CW	SW	TW	mA
				50	35	10	5	
V_{GT}			MAX	1.5				V
V_{GD}	$V_D = V_{DRM}$ $R_L = 3.3\text{ k}\Omega$, $T_j = 125^\circ\text{C}$		MIN	0.2				V
I_H	$I_T = 100\text{ mA}$		MAX	60	40	20	15	mA
I_L	$I_G = 1.2 \times I_{GT}$		MAX	100	60	40	30	mA
dv/dt	$V_D = 67\% V_{DRM}$, gate open, $T_j = 125^\circ\text{C}$		MIN	500	500	200	100	V/ μs
$(dv/dt)_c$	Critical rise rate of commutation voltage $T_J = 150^\circ\text{C}$		MIN	8				V/ μs

Table 3 Electrical characteristics (T_j = 25 °C unless otherwise specified) -Standard Triac (4 quadrants)

Symbol	Name and test conditions	Quadrant	Range	value		Unit
				B	C	
I _{GT}	V _D =12V R _L =100Ω	I - II -III	MAX	50	20	mA
		IV		100	60	
V _{GT}		ALL	MAX	1.5		V
V _{GD}	V _D = V _{DRM} , R _L = 3.3 kΩ, T _j = 125 ° C	ALL	MIN	0.2		V
I _H	I _T =500mA		MAX	60	50	mA
I _L	I _G = 1.2 x I _{GT}	I - II -III	MAX	60	50	mA
		IV		100	80	
dv/dt	V _D = 67% V _{DRM} , gate open, T _j = 125 ° C		MIN	500		V/us
(dv/dt) _c	Critical rise rate of commutation voltage T _J = 150 ° C		MIN	10		V/us

Static parameters

Symbol	Parameter name			value	Unit
V_{TM}	$I_{TM} = 24A$	$T_j = 25^\circ C$	MAX	1.50	V
V_{TO}	threshold on-state voltage	$T_j = 150^\circ C$	MAX	0.86	V
R_d	Dynamic resistance	$T_j = 150^\circ C$	MAX	36.6	mΩ
I_{DRM} I_{RRM}	VDRM = VRRM	$T_j = 25$	MAX	5	uA
		$T_j = 150$		1	mA
$R_{th(j-c)}$	Junction to ambient	BTA	MAX	2.05	°C W

BTA12 characteristic curve

FIG.1 Maximum power dissipation versus RMS on-state current

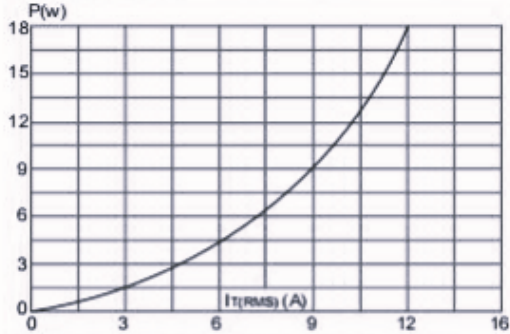

FIG.3: Surge peak on-state current versus number of cycles

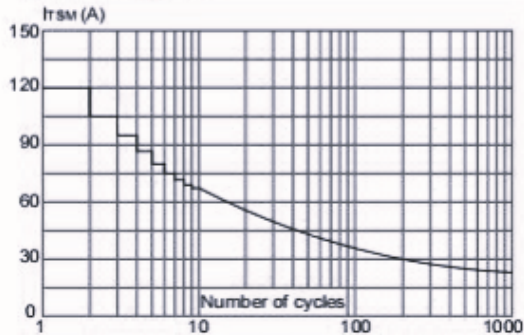

FIG.5: Non-repetitive surge peak on-state current for a sinusoidal pulse with width $t_p < 10\text{ms}$, and corresponding value of $I^2 t$ ($di/dt < 50\text{A}/\mu\text{s}$)

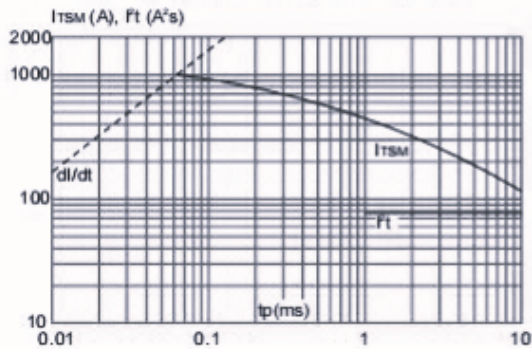

FIG.2: RMS on-state current versus case temperature

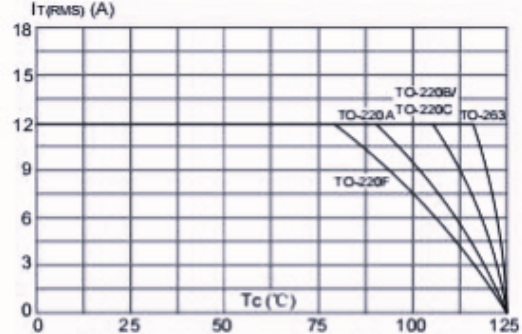

FIG.4: On-state characteristics (maximum values)

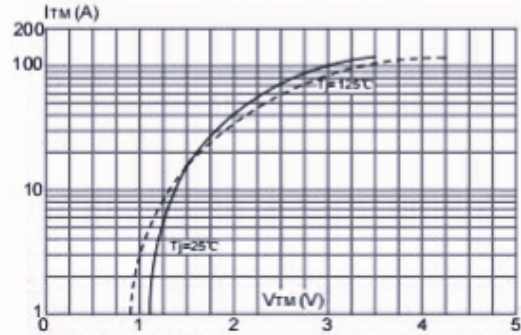
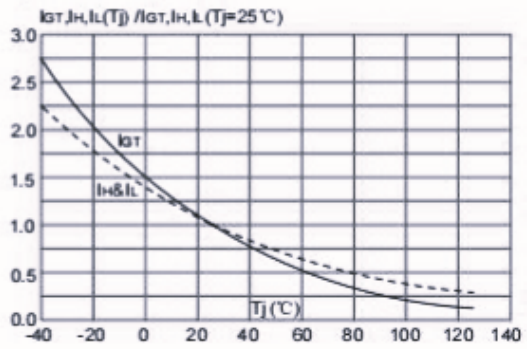
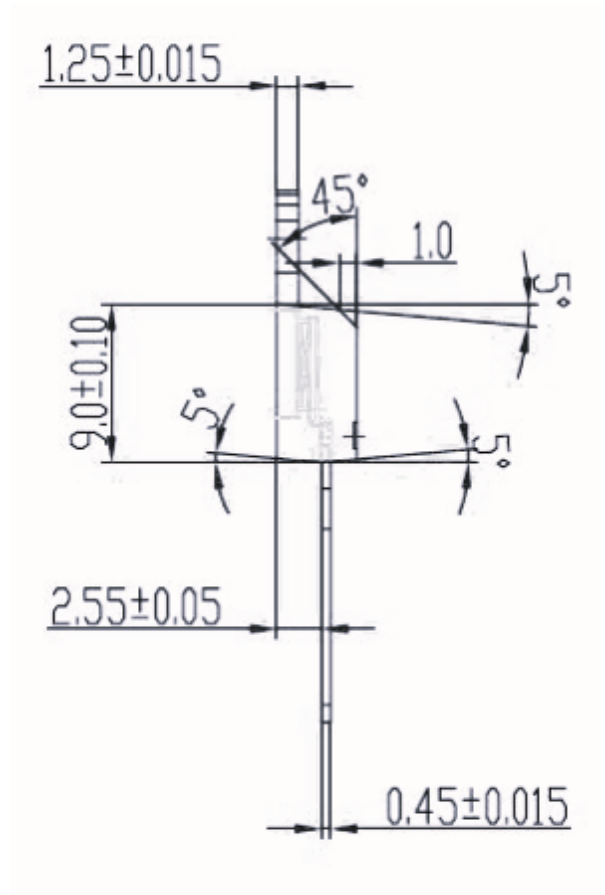
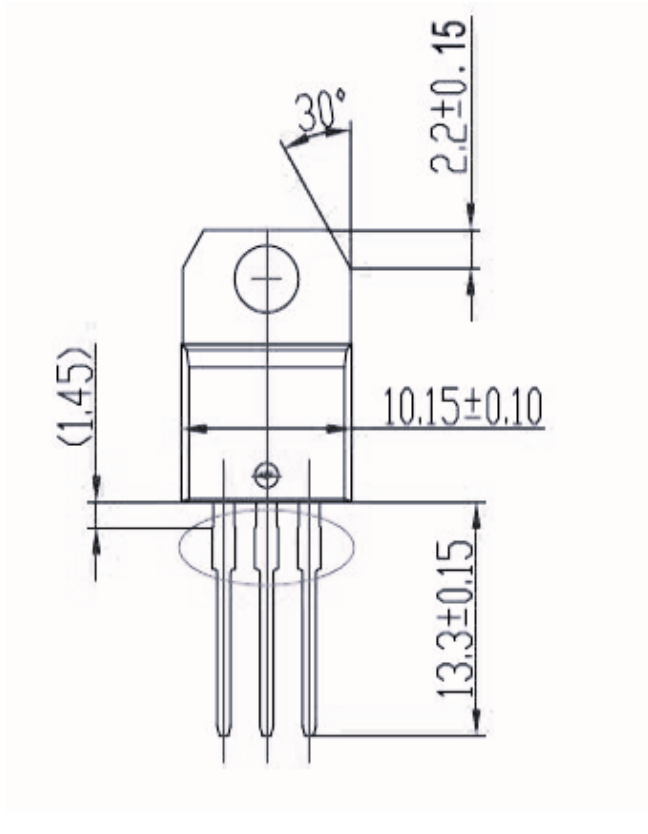

FIG.6: Relative variations of gate trigger current, holding current and latching current versus junction temperature



TO-220 Dimensional drawing:

Unit: mm (± 0.1)



Ordering information

Order code	Package	Baseqty	Deliverymode
BTA12-600BRG	TO-220A	1000	Tube and box
BTA12-600CRG	TO-220A	1000	Tube and box
BTA12-800BRG	TO-220A	1000	Tube and box
BTA12-800CRG	TO-220A	1000	Tube and box
BTA12-600BWRG	TO-220A	1000	Tube and box
BTA12-600CWRG	TO-220A	1000	Tube and box
BTA12-800BWRG	TO-220A	1000	Tube and box
BTA12-800CWRG	TO-220A	1000	Tube and box
BTA12-600SWRG	TO-220A	1000	Tube and box
BTA12-600TWRG	TO-220A	1000	Tube and box
BTA12-800SWRG	TO-220A	1000	Tube and box