

Description

The IRFH9310 uses advanced trench technology to provide excellent $R_{DS(ON)}$, low gate charge and operation with gate voltages as low as 4.5V. This device is suitable for use as a Battery protection or in other Switching application.

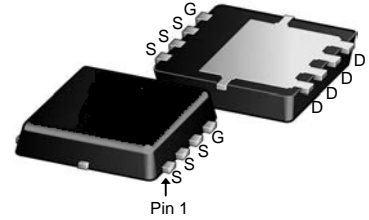

DFN5X6-8L

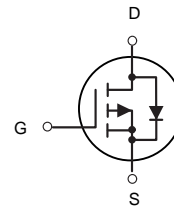

P-Channel MOSFET

General Features

$V_{DS} = -30V$ $I_D = -90A$

$R_{DS(ON)} < 4.5\ m\Omega$ $V_{GS} = -10V$

Application

Battery protection

Load switch

Uninterruptible power supply

Package Marking and Ordering Information

Product ID	Pack	Marking	Qty(PCS)
IRFH9310	DFN5X6-8L	IRFH9310 XXXX	5000

Absolute Maximum Ratings ($T_C=25^\circ C$ unless otherwise noted)

Symbol	Parameter	Rating	Units
V_{DS}	Drain-Source Voltage	-30	V
V_{GS}	Gate-Source Voltage	± 20	V
$I_D@T_C=25^\circ C$	Continuous Drain Current, $V_{GS} @ 10V^1$	-90	A
$I_D@T_C=100^\circ C$	Continuous Drain Current, $V_{GS} @ 10V^1$	-57	A
I_{DM}	Pulsed Drain Current ²	-360	A
EAS	Single Pulse Avalanche Energy ³	125	mJ
$P_D@T_C=25^\circ C$	Total Power Dissipation ⁴	60	W
T_{STG}	Storage Temperature Range	-55 to 150	$^\circ C$
T_J	Operating Junction Temperature Range	-55 to 150	$^\circ C$
$R_{\theta JA}$	Thermal Resistance Junction-Ambient ¹	55	$^\circ C/W$
$R_{\theta JC}$	Thermal Resistance Junction-Case ¹	2.08	$^\circ C/W$

Electrical Characteristics ($T_J = 25^\circ\text{C}$, unless otherwise noted)

Parameter	Symbol	Test Conditions	Min.	Typ.	Max.	Unit	
Drain-Source Breakdown Voltage	$V_{(BR)DSS}$	$V_{GS} = 0V, I_D = -250\mu A$	-30	-	-	V	
Gate-body Leakage current	I_{GSS}	$V_{DS} = 0V, V_{GS} = \pm 20V$	-	-	± 100	nA	
Zero Gate Voltage Drain Current	I_{DSS}	$V_{DS} = -30V, V_{GS} = 0V$	$T_J = 25^\circ\text{C}$	-	-	-1	μA
			$T_J = 100^\circ\text{C}$	-	-	-100	
Gate-Threshold Voltage	$V_{GS(th)}$	$V_{DS} = V_{GS}, I_D = -250\mu A$	-1.0	-1.6	-2.5	V	
Drain-Source On-Resistance ⁴	$R_{DS(on)}$	$V_{GS} = -10V, I_D = -30A$	-	3.5	4.5	m Ω	
		$V_{GS} = -4.5V, I_D = -15A$	-	4.8	6.2		
Forward Transconductance ⁴	g_{fs}	$V_{DS} = -10V, I_D = -30A$	-	90	-	S	
Input Capacitance	C_{iss}	$V_{DS} = -15V, V_{GS} = 0V, f = 1\text{MHz}$	-	5070	-	pF	
Output Capacitance	C_{oss}		-	695	-		
Reverse Transfer Capacitance	C_{rss}		-	580	-		
Gate resistance	R_g	$f = 1\text{MHz}$	-	4	-	Ω	
Total Gate Charge	Q_g	$V_{GS} = -10V, V_{DS} = -15V, I_D = -30A$	-	146	-	nC	
Gate-Source Charge	Q_{gs}		-	21.5	-		
Gate-Drain Charge	Q_{gd}		-	39	-		
Turn-On Delay Time	$t_{d(on)}$	$V_{GS} = -10V, V_{DD} = -15V, R_G = 3\Omega, I_D = -30A$	-	23	-	ns	
Rise Time	t_r		-	15	-		
Turn-Off Delay Time	$t_{d(off)}$		-	129	-		
Fall Time	t_f		-	28	-		
Diode Forward Voltage ⁴	V_{SD}	$I_S = -30A, V_{GS} = 0V$	-	-	-1.2	V	
Continuous Source Current	I_S	$T_C = 25^\circ\text{C}$	-	-	-90	A	

Note :

1. Repetitive rating, pulse width limited by junction temperature $T_{J(MAX)} = 150^\circ\text{C}$
2. The EAS data shows Max. rating . The test condition is $V_{DD} = -25V, V_{GS} = -10V, L = 0.1\text{mH}, I_{AS} = -50A$
3. The data tested by surface mounted on a 1 inch² FR-4 board with 2OZ copper, The value in any given application depends on the user's specific board design.

Typical Characteristics

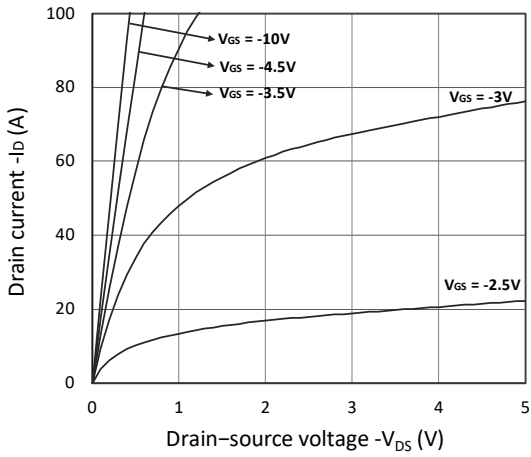

Figure 1. Output Characteristics

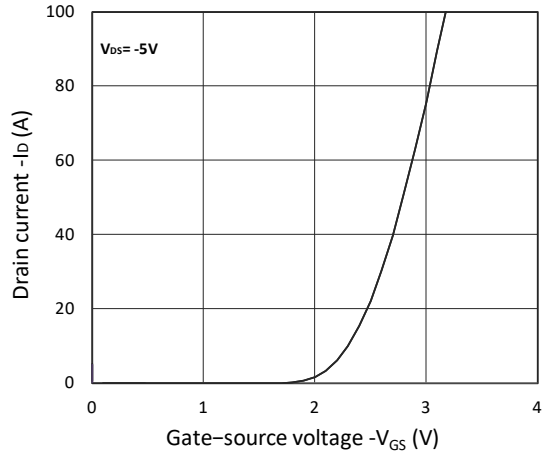

Figure 2. Transfer Characteristics

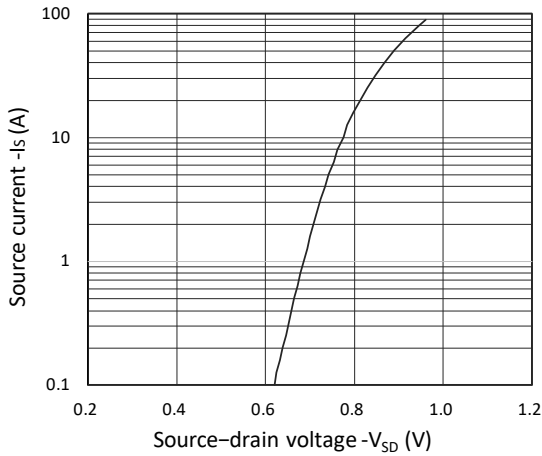

Figure 3. Forward Characteristics of Reverse

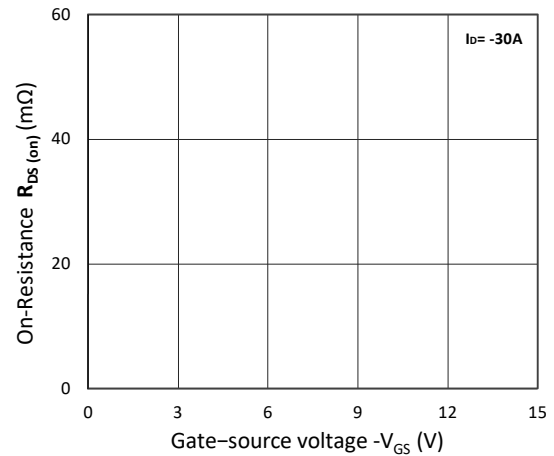

Figure 4. $R_{DS(on)}$ vs. V_{GS}

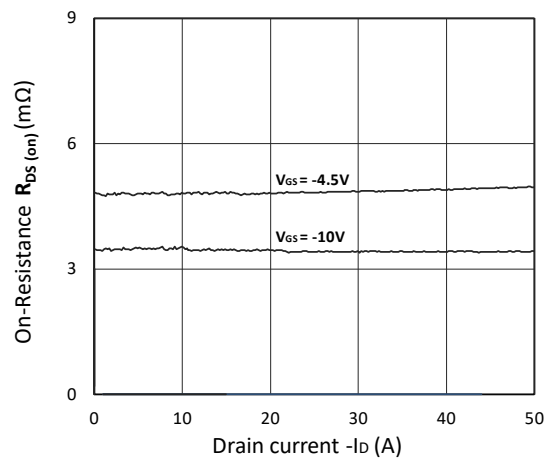

Figure 5. $R_{DS(on)}$ vs. I_D

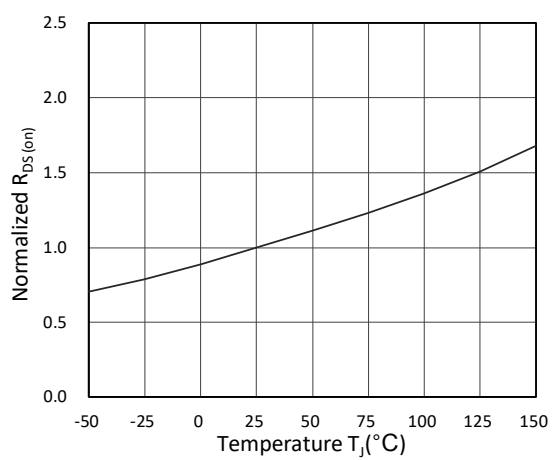

Figure 6. Normalized $R_{DS(on)}$ vs. Temperature

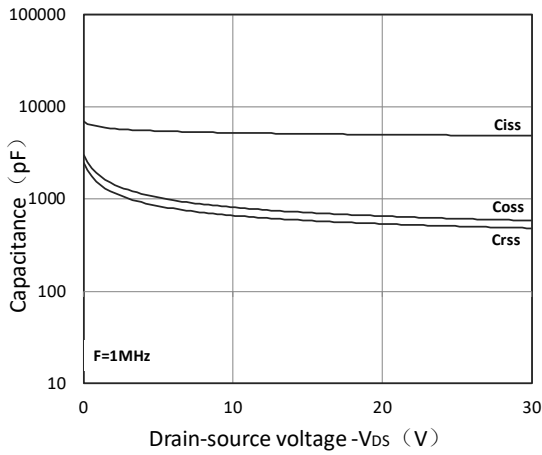

Figure 7. Capacitance Characteristics

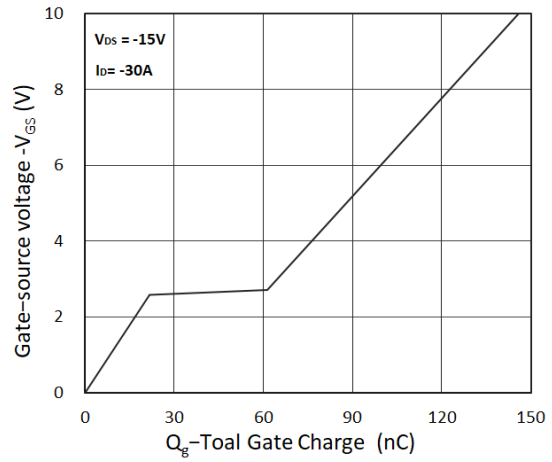

Figure 8. Gate Charge Characteristics

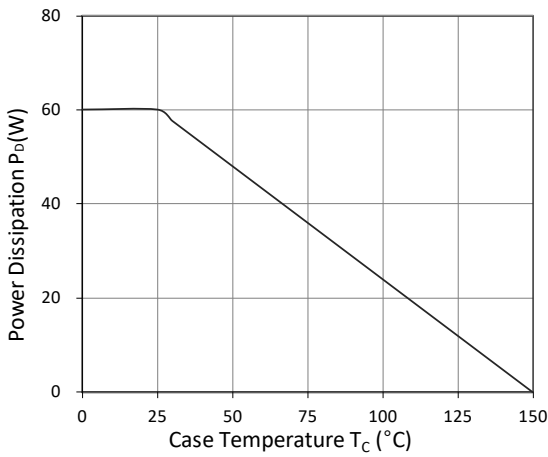

Figure 9. Power Dissipation

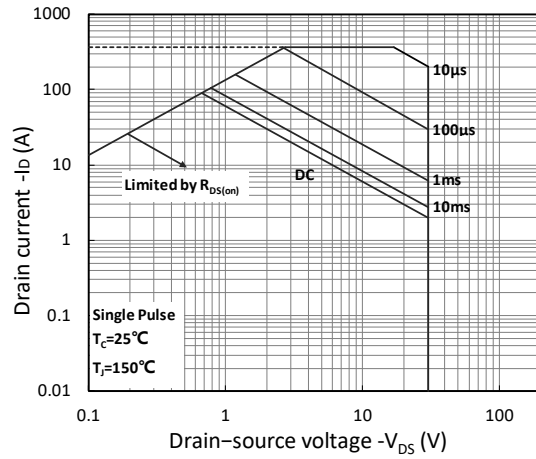

Figure 10. Safe Operating Area

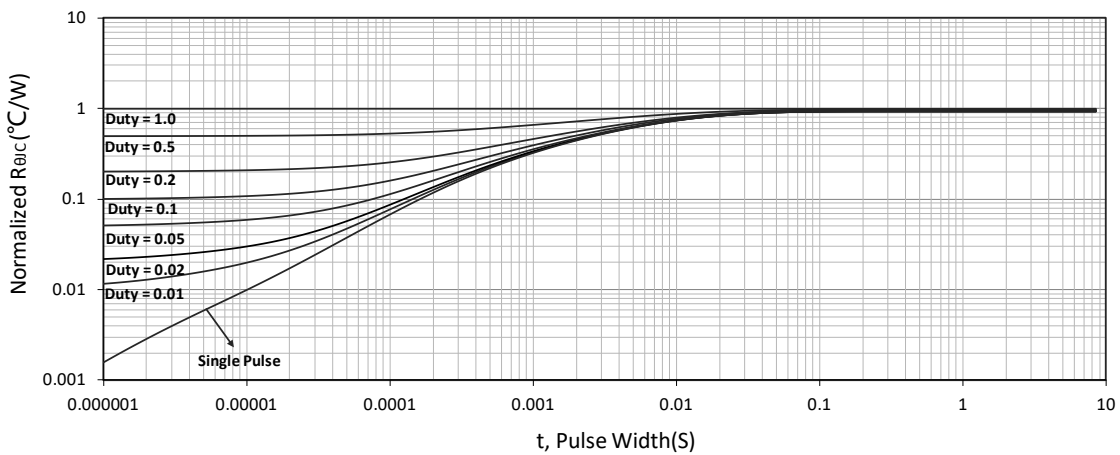

Figure 11. Normalized Maximum Transient Thermal Impedance

Test Circuit

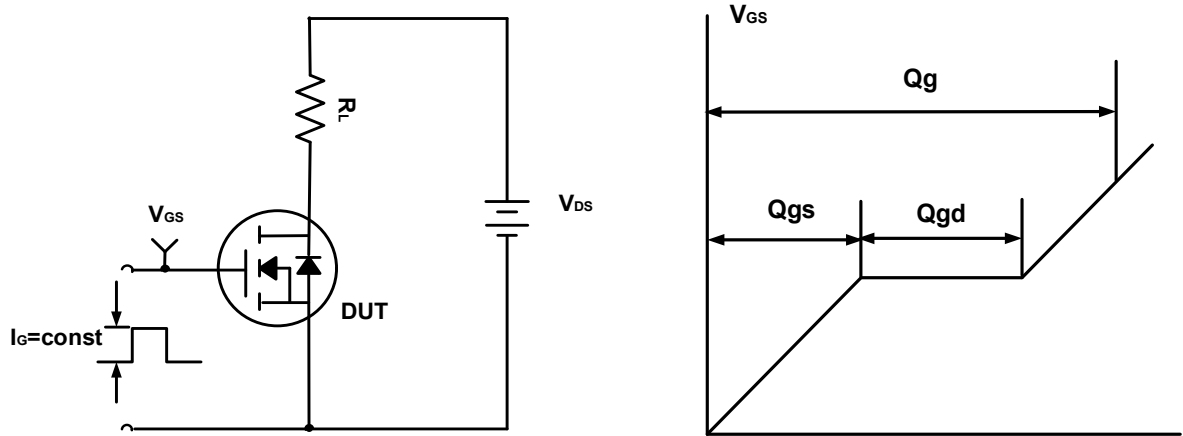

Figure A. Gate Charge Test Circuit & Waveforms

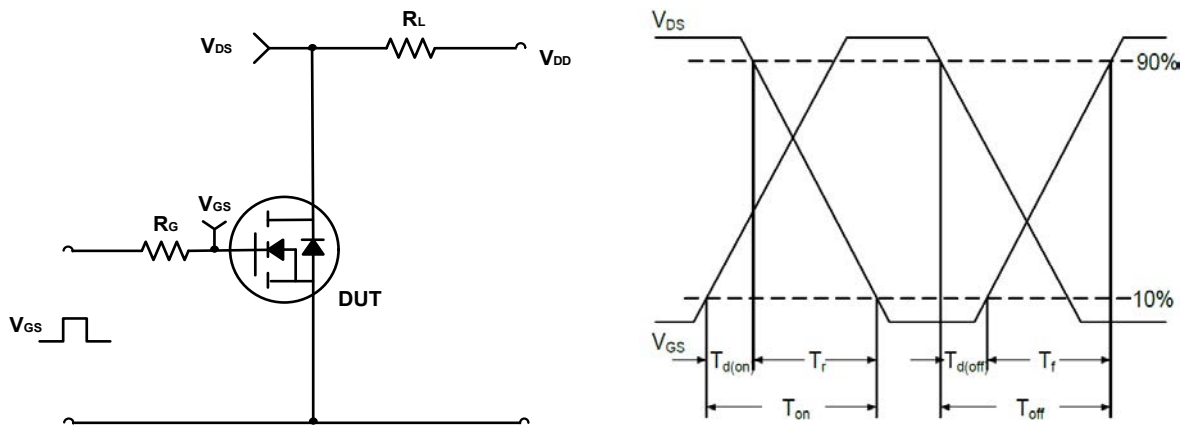

Figure B. Switching Test Circuit & Waveforms

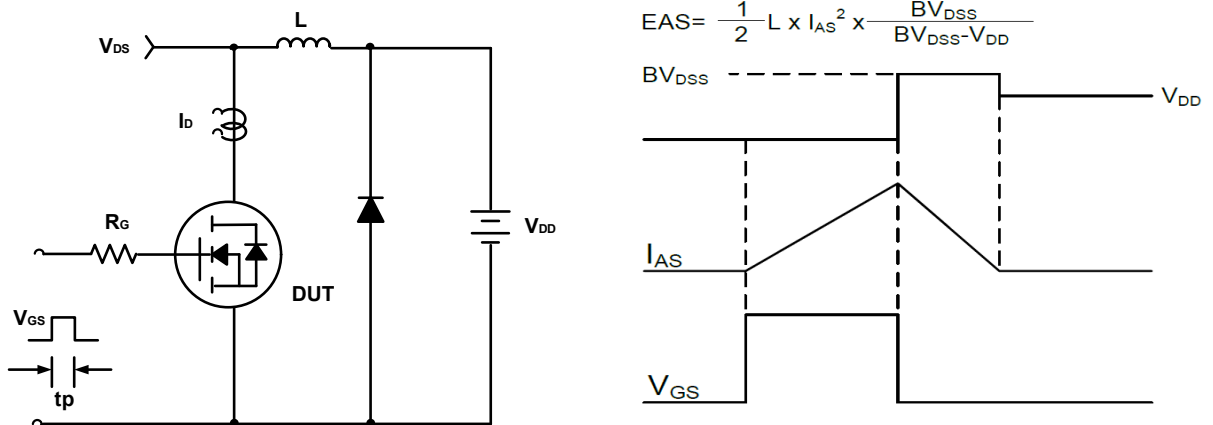
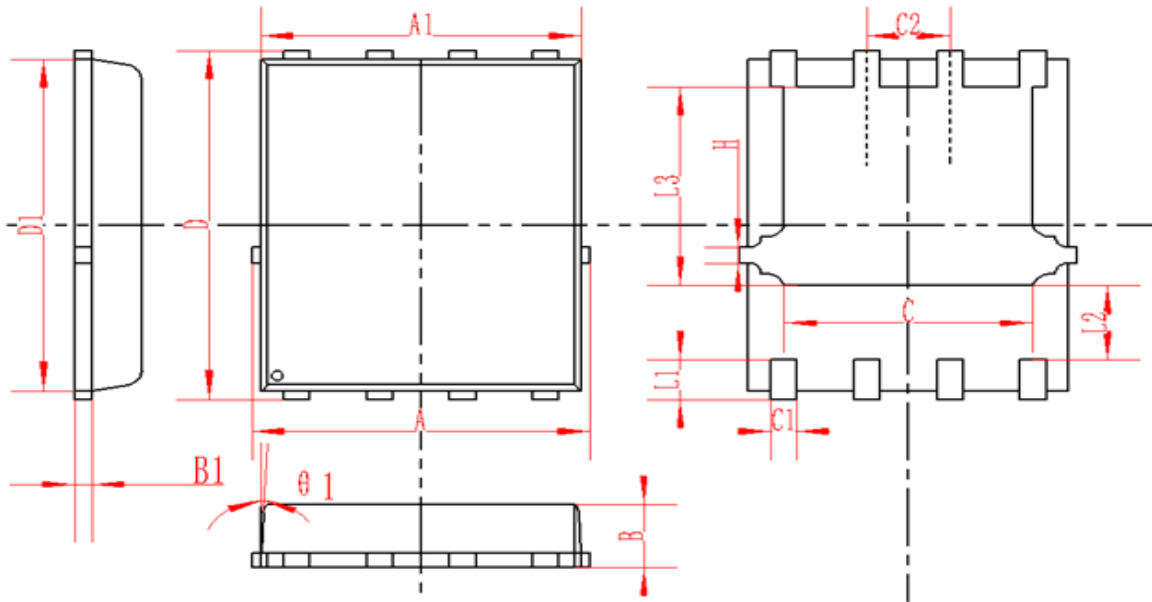

Figure C. Unclamped Inductive Switching Circuit & Waveforms

DFN5X6-8L Package Information



SYMBOL	MM			INCH		
	MIN	NOM	MAX	MIN	NOM	MAX
A	4.95	5	5.05	0.195	0.197	0.199
A1	4.82	4.9	4.98	0.190	0.193	0.196
D	5.98	6	6.02	0.235	0.236	0.237
D1	5.67	5.75	5.83	0.223	0.226	0.230
B	0.9	0.95	1	0.035	0.037	0.039
B1	0.254REF			0.010REF		
C	3.95	4	4.05	0.156	0.157	0.159
C1	0.35	0.4	0.45	0.014	0.016	0.018
C2	1.27TYP			0.5TYP		
θ1	8°	10°	12°	8°	10°	12°
L1	0.63	0.64	0.65	0.025	0.025	0.026
L2	1.2	1.3	1.4	0.047	0.051	0.055
L3	3.415	3.42	3.425	0.134	0.135	0.135
H	0.24	0.25	0.26	0.009	0.010	0.010