

# EVVOSEMI<sup>®</sup>

THINK CHANGE DO



ESD



TVS



MOS



LDO

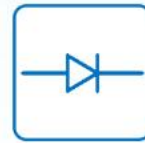

Diode

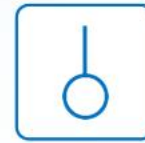

Sensor



DC-DC

## Product Specification

▶ Domestic	Part Number	MAX809
▶ Overseas	Part Number	MAX809
▶ Equivalent	Part Number	MAX809

EV is the abbreviation of name EVVO

## Microprocessor voltage detection reset chip

### SUMMARY

MAX809 is a voltage detection chip used for voltage monitoring of digital system power supply, which can work in industrial standard temperature range.

MAX809 generates a reset signal, which goes low when the system power supply voltage drops to the set value. When the system power supply voltage returns to the set value, the chip will set the reset signal high after a delay time of at least 140ms. MAX809 series products can provide any set detection voltage required by customers. At present, we will provide 7 for 5.0V, 3.3V, 3.0V and 2. Standard industrial voltage monitoring values of four kinds of 5V power supply voltages.

MAX809 provides an output stage with push-pull structure, which resets the output high level when the voltage to be monitored is higher than the set voltage value.

The jitter and burr of the fast power supply transient will be filtered out by this chip, which will not cause misoperation. At the same time, even if the power supply voltage is as low as 1.0V, the normal output logic and various performance indexes can be guaranteed.

MAX809 provides a compact 3-pin package SOT-23.

### Peculiarity

- ◆ It can work in the industrial temperature range:  $-40^{\circ}\text{C}$  to  $+85^{\circ}\text{C}$
- ◆ It can work normally as low as 1V.
- ◆ Power supply burr interference shielding function
- ◆ Available in SOT-23 package
- ◆ Meets lead-free and RoHS requirements.

### Typical application

### Applied range

- ◆ Computers, servers, notebooks, modems
- ◆ Wireless switch
- ◆ embedded system
- ◆ Household appliances, electric meters
- ◆ And PDA and handheld devices.

MAX809 adopts SOT 23.

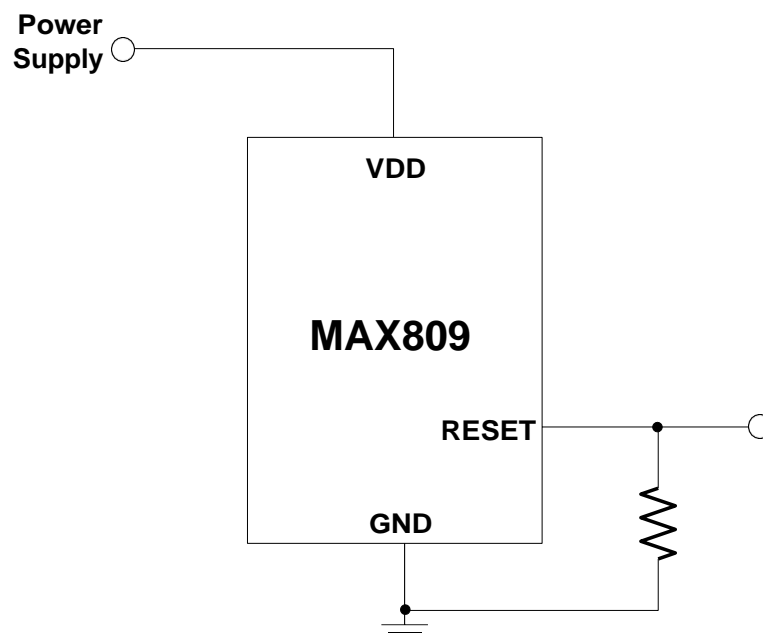

Microprocessor voltage  
detection reset chip

Marking instructions and pin distribution

**SOT-23**

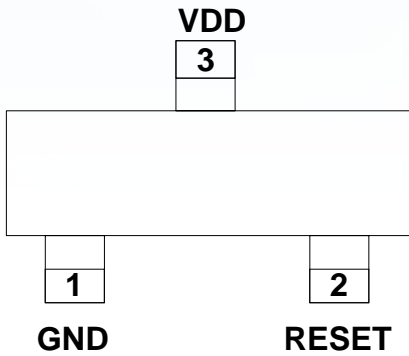

Pin description

serial number	name	explain
1	GND	Grounding foot.
2	RESET	Reset the model output pin. The RESET VDD will go low when it is lower than the reset threshold voltage, and will go high after a delay of at least 140ms when VDD rises to the reset threshold voltage.
3	VDD	Chip power supply and voltage input pin to be detected.

■ Model selection

mode 1	Maximum input voltage (v)	Reset voltage (v)	allowance	silk-screen	package
MAX809T	5.5	3.08	±2%	ACAA	SOT23 SOT89-3
MAX809S	5.5	2.93	±2%	ADAA	
MAX809R	5.5	2.63	±2%	AFAA	

Microprocessor voltage  
detection reset chip

structured flowchart

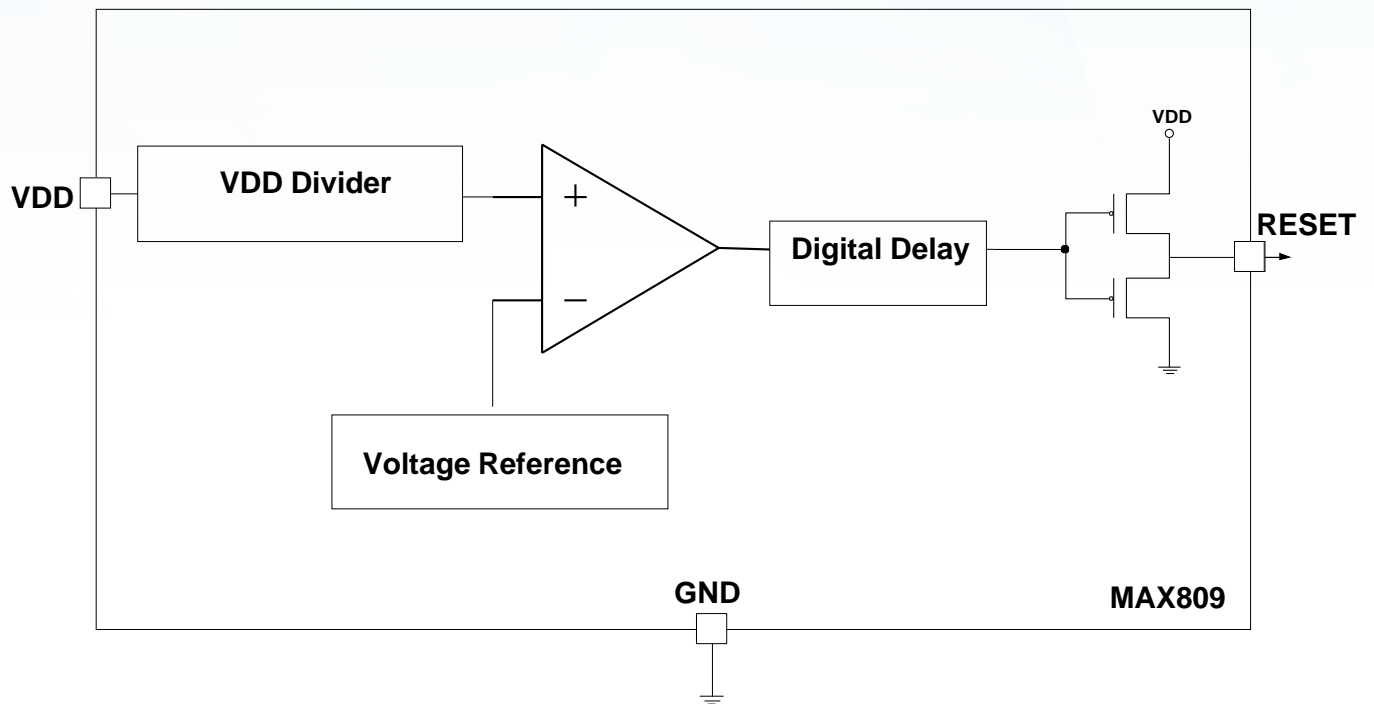

## Microprocessor voltage detection reset chip

### Maximum rating (note)

parameter		symbol	range	unit
All feet butt to ground.			-0.3 to +6.0	V
VDD input current			20	mA
RESET output current			20	mA
VDD rising rate			100	V/s
Continuous dissipated power, ambient temperature At 25°C, 4 mW/°C will be reduced when the temperature exceeds 70°C	SOT-23	PD	320	mW
Thermal resistance, junction to air	SOT-23	R <sub>θJA</sub>	270	°C /W
operating temperature range		T <sub>J</sub>	-40 ~ +125	°C
Storage temperature range		T <sub>stg</sub>	-65 ~ +150	°C
Welding temperature (10 seconds)		T <sub>sol</sub>	300	°C
Reflow soldering temperature				°C
Gas phase heating (60 seconds)		T <sub>vap</sub>	215	°C
Infrared heating (15 seconds)		T <sub>inf</sub>	220	°C
ESD protection	Human body Mode (HBM): According to JESD22-A114		4000	V
	Machine Mode (MM): According to JESD22-A115		400	
Maximum rated Latchup current: JESD78 Class II	Reverse	I <sub>Latchup</sub> p	200	mA
			200	
			200	

Note: Application conditions exceeding the "absolute maximum rating" listed in the above table may permanently damage the chip. This only refers to the rated limit index, and does not imply that customers can apply this chip under this condition or any other conditions exceeding the "recommended working conditions". All applications exceeding the "absolute maximum rating" will affect the reliability of this chip.

Microprocessor voltage  
 detection reset chip

## electrical specification

(unless otherwise specified, ambient temperature TA=25°C)

symbol	parameter	test condition	minimum value	typical value	maximum	unit	
VDD	input voltage		1.0		5.5	V	
I <sub>VDD</sub>	operational current	VDD=2.0V		8		uA	
		VDD=3.0V		10			
		VDD=5.0V		14			
V <sub>RST</sub>	Reset threshold voltage (VDD rises)	L-shaped	TA=25°C	4.537	4.63	4.723	V
			TA=-40°C~+125°C	4.40		4.86	
		M type	TA=25°C	4.292	4.38	4.468	
			TA=-40°C~+125°C	4.16	4.00	4.56	
		J type	TA=25°C	3.92		4.08	
			TA=-40°C~+125°C	3.80		4.20	
		T-shaped	TA=25°C	3.003	3.08	3.157	
			TA=-40°C~+125°C	2.92		3.23	
		S type	TA=25°C	2.857	2.93	3.003	
			TA=-40°C~+125°C	2.78		3.08	
		R type	TA=25°C	2.564	2.63	2.696	
			TA=-40°C~+125°C	2.50		2.76	
Z type	TA=25°C	2.262	2.32	2.378			
	TA=-40°C~+125°C	2.22		2.42			
TC	Reset voltage temperature coefficient			30		ppm	
TR	Reset delay time	VDD rising	150	240	560	ms	
V <sub>HYS</sub>	Reset voltage hysteresis range	VDD drops		95%V <sub>RST</sub>		V	
TD	Reset shutdown delay time	The VDD is from V <sub>RST</sub> to (V <sub>RST</sub> -100mV)		20		us	
V <sub>OL</sub>	Reset pin low level	VDD=2V, V <sub>RST</sub> >2V Inflow of 1.5mA			0.3	V	
		VDD=3V, V <sub>RST</sub> >3V Inflow of 3.2mA			0.3		
		VDD=4V, V <sub>RST</sub> >4V Inflow 5mA			0.3		
V <sub>OH</sub>	Reset pin high level	VDD=3V, V <sub>RST</sub> >3V Outflow of 1.2mA	VDD-0.4			V	
		VDD=4V, V <sub>RST</sub> >4V Outflow 2mA	VDD-0.4				
		VDD=5V, V <sub>RST</sub> >5V Outflow 2.5mA	VDD-0.4				

## Microprocessor voltage detection reset chip

### instructions

The reset signal will give the microprocessor a certain initial state, and the MAX809 will give such a reset signal to prevent the microprocessor from making code execution errors in the process of power-on, power-off or power-off. MAX809 will give a reset signal (low level) after the VDD supply voltage drops to a preset threshold voltage, The signal level will be maintained for at least 140ms even if the VDD supply voltage is higher than the preset threshold voltage.

MAX809 series microprocessor reset detection chip is used to monitor the power supply voltage of digital system. It can provide a reset signal to the processor without any external devices. The following figure shows the timing diagram of a typical application. Assuming that the initial input VDD is at a normal voltage value higher than the preset reset recovery voltage (VRST), At this time, the RESET pin (pin 2) is at a high level. If the VDD voltage drops significantly due to the interruption of an input power supply and is lower than the RESET shutdown voltage (VHYST), the reset pin will output a low level at this time. When the power supply interruption is over, after VDD returns to a normal voltage value higher than the reset recovery voltage (VRST), the internal delay response counter will be triggered. When the counting time (TR) is over, The RESET pin (pin 2) will output the high level again.

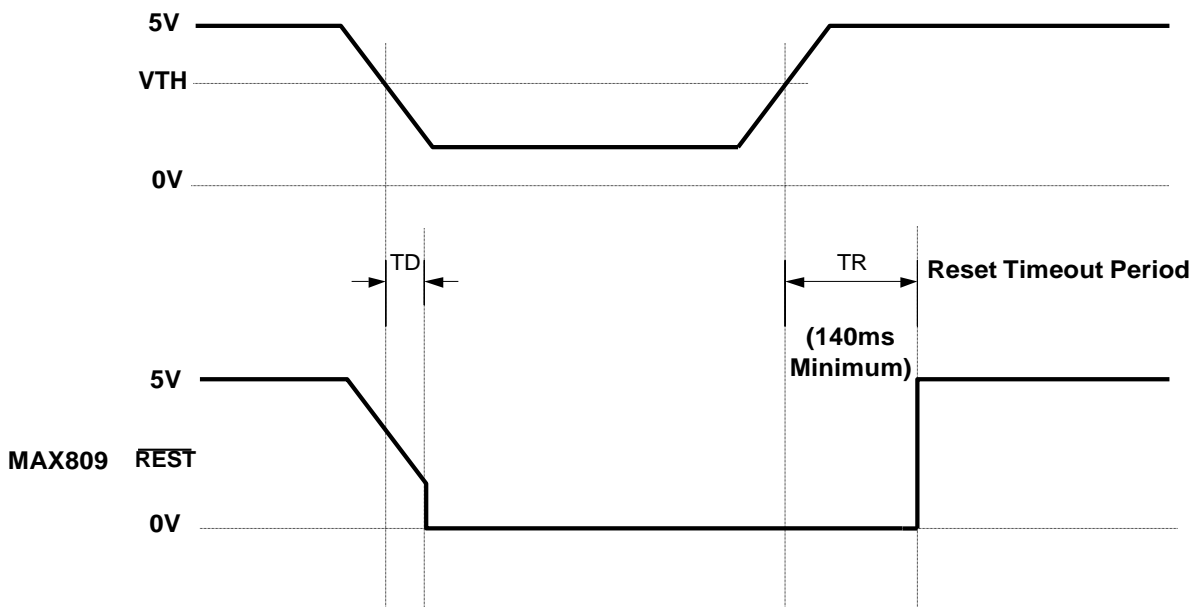



## Microprocessor voltage detection reset chip

### Application information

#### •VDD burr shielding function

MAX809 provides accurate VDD voltage detection and reset delay function to shield the transient jitter of VDD when the power supply is powered up, powered down, powered down and the power peak undershoots. The shielding function of power supply glitch can be effectively improved by increasing the capacitance at the position as close as possible to the VDD pin.

#### •Ensure that the RESET output is normal when VDD is reduced to 0V.

The RESET output of MAX809 can work normally when the power supply is as low as 1V. When the power supply is lower than 1V, the RESET presents an open circuit because it no longer pulls down the current. This means that the CMOS logic input to the microprocessor will be at a floating indefinite voltage.

Most digital systems will be completely shut down when they are higher than 1V. Even so, when VDD=0V, the RESET pin should remain active. At this time, it is necessary to add a pull-down resistor to the RESET pin to discharge the residual charge on the stray capacitance and keep the output low. This pull-down resistance value, though not critical, however, it should still be ensured that it will not affect the normal operation of RESET (100 k $\Omega$  is large enough without increasing the load requirement when RESET is high, and small enough to pull it down to the ground when RESET is low).

#### •The advantage of high threshold precision

Most microprocessors detect that the reset threshold voltage of IC is between 5% and 10%, which can ensure that the reset action will not occur within the range of 5% power supply voltage down, but will occur within the range of 10% power supply voltage down.

When an IC with a normal power supply voltage rating of 5% is used, there will be an uncertain area when the power supply voltage is 5% to 10% lower than the normal value, and the reset action may or may not occur. MAX809 uses a high-precision circuit, which can ensure that the reset action takes place near the 5% power supply voltage sag window, but far away from the 10% power supply voltage sag window.



Microprocessor voltage  
detection reset chip

Package description: SOT-23

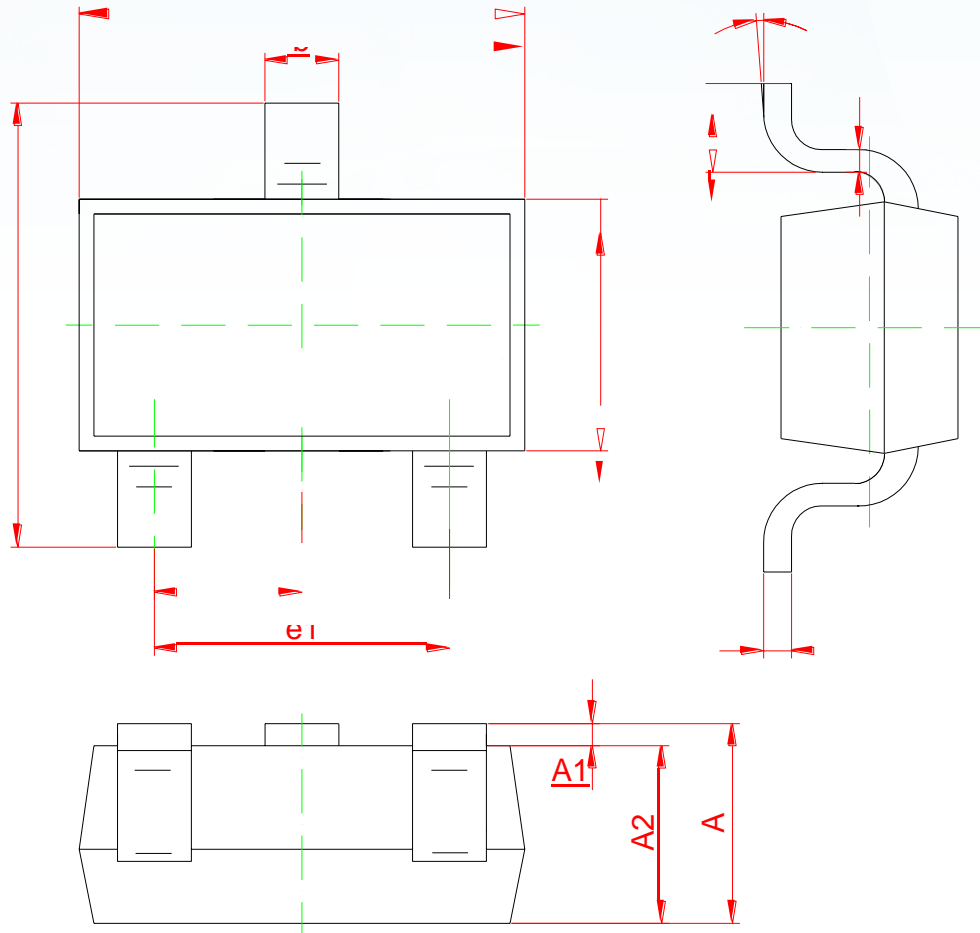

Symbol	Dimensions In Millimeters	
	Min	Max
A1	0.02	0.1
A2	1.0Typical	
b	0.4Typical	
c	0.1Typical	
D	2.70	3.10
E	1.10	1.50
E1	2.20	2.60
e1	1.80	2.00
L	0.35	0.48

## Disclaimer

EVOSEMI ("EVVO") reserves the right to make corrections, enhancements, improvements, and other changes to its products and services at any time, and to discontinue any product or service without notice.

EVVO warrants the performance of its hardware products to the specifications applicable at the time of sale in accordance with its standard warranty. Testing and other quality control techniques are used as deemed necessary by EVVO to support this warranty. Except where mandated by government requirements, testing of all parameters of each product is not necessarily performed.

Customers should obtain and confirm the latest product information and specifications before final design, purchase, or use. EVVO makes no warranty, representation, or guarantee regarding the suitability of its products for any particular purpose, nor does EVVO assume any liability for application assistance or customer product design. EVVO does not warrant or accept any liability for products that are purchased or used for any unintended or unauthorized application.

EVVO products are not authorized for use as critical components in life support devices or systems without the express written approval of EVOSEMI.

The EVVO logo and EVOSEMI are trademarks of EVOSEMI or its subsidiaries in relevant jurisdictions. EVVO reserves the right to make changes without further notice to any products herein.