

EVVOSEMI[®]

THINK CHANGE DO



ESD



TVS



MOS



LDO



Diode



Sensor



DC-DC

Product Specification

▶ Domestic	Part Number	MAX3232CSE
▶ Overseas	Part Number	MAX3232CSE
▶ Equivalent	Part Number	MAX3232CSE

EV is the abbreviation of name EVVO

3.0V TO 5.5V LOW POWER MULTICHANNEL RS-232 LINE TRANSCEIVERS USING FOR 0.1 μ F EXTERNAL CAPACITORS

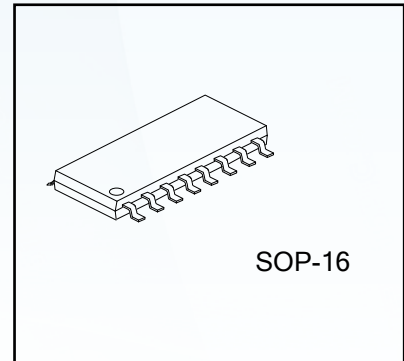

DESCRIPTION

The MAX3232CSE has two receivers and two drivers, and a dual charge-pump circuit. The device meets the requirements of TIA/EIA-232-F and provides the electrical interface between an asynchronous communication controller and the serial-port connector. The charge pump and four small external capacitors allow operation from a single 3.0V to 5.5V supply. The device operates at data signaling rates up to 250kbit/s and a maximum of 35V/ μ s driver output slew rate.

FEATURES

- * Exceeds \pm 8KV ESD Protection(HBM) for RS-232 I/O Pins
- * Meets the Requirements of TIA/EIA-232-F and ITU V.28 Standards
- * Operates With 3.0V to 5.5V V_{CC} Supply
- * Operates Up To 250kbit/s Data Rate
- * Two Drivers and Two Receivers
- * External Capacitors 4 \times 0.1 μ F
- * Accepts 5.0V Logic Input With 3.3V Supply

PIN CONFIGURATION

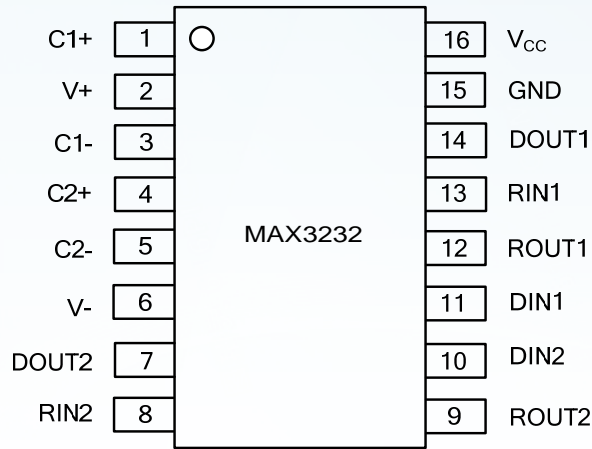

PIN DESCRIPTION

PIN NO.	PIN NAME	DESCRIPTION
1	C1+	Positive Terminal of Voltage-Doubler Charge-Pump Capacitor
2	V+	+5.5V Generated by the Charge Pump
3	C1-	Negative Terminal of Voltage-Doubler Charge-Pump Capacitor
4	C2+	Positive Terminal of Inverting Charge-Pump Capacitor
5	C2-	Negative Terminal of Inverting Charge-Pump Capacitor
6	V-	-5.5V Generated by the Charge Pump
7	DOUT2	RS-232 Driver Outputs
8	RIN2	RS-232 Receiver Inputs
9	ROUT2	TTL/CMOS Receiver Outputs
10	DIN2	TTL/CMOS Driver Inputs
11	DIN1	TTL/CMOS Driver Inputs
12	ROUT1	TTL/CMOS Receiver Outputs
13	RIN1	RS-232 Receiver Inputs
14	DOUT1	RS-232 Driver Outputs
15	GND	Ground
16	V _{CC}	+3.0V to +5.5V Supply Voltage

BLOCK DIAGRAM

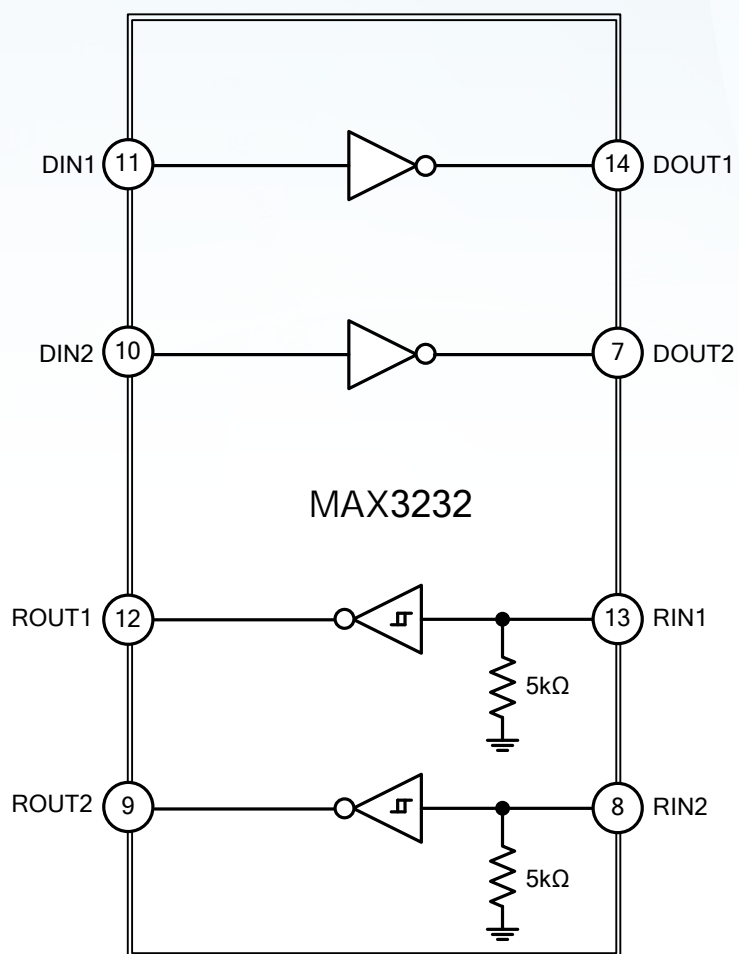

ABSOLUTE MAXIMUM RATING [Over operating free-air temperature range (unless otherwise noted)]

PARAMETER		SYMBOL	RATINGS	UNIT
Supply Voltage Range		V_{CC}	-0.3 ~ +6.0	V
Positive Output Supply Voltage Range (Note 2)		V+	-0.3 ~ +7.0	V
Negative Output Supply Voltage Range (Note 2)		V-	+0.3 ~ -7.0	V
Supply Voltage Difference (Note 2)		V+ - V-	+13	V
Input Voltage	Drivers	V_{IN}	-0.3 ~ +6.0	V
	Receivers		-25 ~ +25	V
Output Voltage	Drivers	V_{OUT}	-13.2 ~ +13.2	V
	Receivers		-0.3 ~ $V_{CC}+0.3$	V
Operating Virtual Junction Temperature		T_J	+150	°C
Storage Temperature		T_{STG}	-65 ~ + 150	°C

- Notes: 1. Absolute maximum ratings are those values beyond which the device could be permanently damaged. Absolute maximum ratings are stress ratings only and functional device operation is not implied.
 2. All voltages are with respect to network GND.

THERMAL DATA

PARAMETER		SYMBOL	RATING	UNIT
Junction to Ambient	SOP-16	θ_{JA}	105	°C/W

RECOMMENDED OPERATING CONDITIONS (See Note & Table 1)

PARAMETER	SYMBOL	TEST CONDITIONS	MIN	TYP	MAX	UNIT
Supply Voltage	V_{CC}	$V_{CC}=3.3V$	3.0	3.3	3.6	V
		$V_{CC}=5.0V$	4.5	5.0	5.5	V
Driver and Control High-level Input Voltage	V_{IH}	DIN	$V_{CC}=3.3V$	2.0		V
			$V_{CC}=5.5V$	2.4		V
Driver and Control Low-level Input Voltage	V_{IL}	DIN			0.8	V
Driver and Control Input Voltage	V_{IN}	DIN			5.5	V
Receiver Input Voltage	V_{RIN}		-25		25	V
Operating Free-Air Temperature	T_A		0		70	°C

Notes: Test conditions are C1~C4=0.1μF at $V_{CC}=3.3V\pm 0.3V$; C1=0.047μF, C2~C4=0.33μF at $V_{CC}=5.0V\pm 0.5V$.

ELECTRICAL CHARACTERISTICS [(over recommended ranges of supply voltage and operating free-air temperature (unless otherwise noted) (see Note 3 & Table 1)]

PARAMETER	SYMBOL	TEST CONDITIONS	MIN	TYP (Note 1)	MAX	UNIT
Supply Current	I_{CC}	No load		0.3	1.0	mA
DRIVER SECTION						
High-Level Output Voltage	V_{OH}	DOUT at $R_L=3k\Omega$ to GND, DIN=GND	+5.0	+5.4		V
Low-Level Output Voltage	V_{OL}	DOUT at $R_L=3k\Omega$ to GND, DIN= V_{CC}	-5.0	-5.4		V
High-Level Input Current	I_{OH}	$V_I=V_{CC}$		± 0.01	± 1	μA
Low-Level Input Current	I_{OL}	V_I at GND		± 0.01	± 1	μA
Short-Circuit Output Current (Note 2)	I_{OS}	$V_{CC}=3.6V, V_{OUT}=0V$		± 35	± 60	mA
		$V_{CC}=5.5V, V_{OUT}=0V$		± 35	± 60	mA
Output Resistance	r_O	$V_{CC}, V+$ and $V- =0V, V_{OUT}=\pm 2.0V$	300	10M		Ω
RECEIVER SECTION						
High-Level Output Voltage	V_{OH}	$I_{OH}=-1.0mA$	$V_{CC}-0.6V$	$V_{CC}-0.1V$		V
Low-Level Output Voltage	V_{OL}	$I_{OL}=1.6mA$			0.4	V
Positive-Going Input Threshold Voltage	V_{IT+}	$V_{CC}=3.3V$		1.5	2.4	V
		$V_{CC}=5.0V$		1.8	2.4	V
Negative-Going Input Threshold Voltage	V_{IT-}	$V_{CC}=3.3V$	0.6	1.2		V
		$V_{CC}=5.0V$	0.8	1.5		V
Input Hysteresis	V_{HYS}	$V_{IT+}-V_{IT-}$		0.3		V
Input Resistance	R_I	$V_I=\pm 3.0V \sim \pm 25V$	3	5	7	k Ω

Notes: 1. All typical values are at $V_{CC}=3.3V$ or $V_{CC}=5.0V$, and $T_A=25^\circ C$.

- Short-circuit durations should be controlled to prevent exceeding the device absolute power-dissipation ratings, and not more than one output should be shorted at a time.
- Test conditions are $C1 \sim C4=0.1\mu F$ at $V_{CC}=3.3V \pm 0.3V$; $C1=0.047\mu F, C2 \sim C4=0.33\mu F$ at $V_{CC}=5.0V \pm 0.5V$.
- Pulse skew is defined as $|t_{PLH}-t_{PHL}|$ of each channel of the same device.

SWITCHING CHARACTERISTICS [(over recommended ranges of supply voltage and operating free-air temperature (unless otherwise noted) (see Note 3 and Table 1)]

PARAMETER	SYMBOL	TEST CONDITIONS	MIN	TYP (Note 1)	MAX	UNIT
DRIVER SECTION						
Maximum Data Rate		$C_L=1000pF, R_L=3k\Omega$, One Driver Switching	120		250	Kbit/s
Pulse Skew (Note 4)	$t_{SK(p)}$	$C_L=220pF \sim 2500pF, R_L=3k\Omega \sim 7k\Omega$		300		ns
Slew Rate, Transition Region	SR(tr)	$R_L=3k\Omega \sim 7k\Omega, V_{CC}=3.3V$		5	35	V/ μs
		$C_L=220pF \sim 2500pF$	3		35	
RECEIVER SECTION						
Propagation Delay Time, Low-to High-Level Output	t_{PLH}	$C_L=150pF$		300		ns
Propagation Delay Time, High-to Low-Level Output	t_{PHL}	$C_L=150pF$		300		ns
Output Enable Time	t_{EN}	$C_L=150pF, R_L=3k\Omega$		200		ns
Output Disable Time	t_{DIS}	$C_L=150pF, R_L=3k\Omega$		200		ns
Pulse Skew (Note 4)	$t_{SK(P)}$	$ t_{PLH}-t_{PHL} $		300		ns

Notes: 1. All typical values are at $V_{CC}=3.3V$ or $V_{CC}=5.0V$, and $T_A=25^\circ C$.

- Short-circuit durations should be controlled to prevent exceeding the device absolute power-dissipation ratings, and not more than one output should be shorted at a time.
- Test conditions are $C1 \sim C4=0.1\mu F$ at $V_{CC}=3.3V \pm 0.3V$; $C1=0.047\mu F, C2 \sim C4=0.33\mu F$ at $V_{CC}=5.0V \pm 0.5V$.
- Pulse skew is defined as $|t_{PLH}-t_{PHL}|$ of each channel of the same device.

TYPICAL APPLICATION CIRCUIT

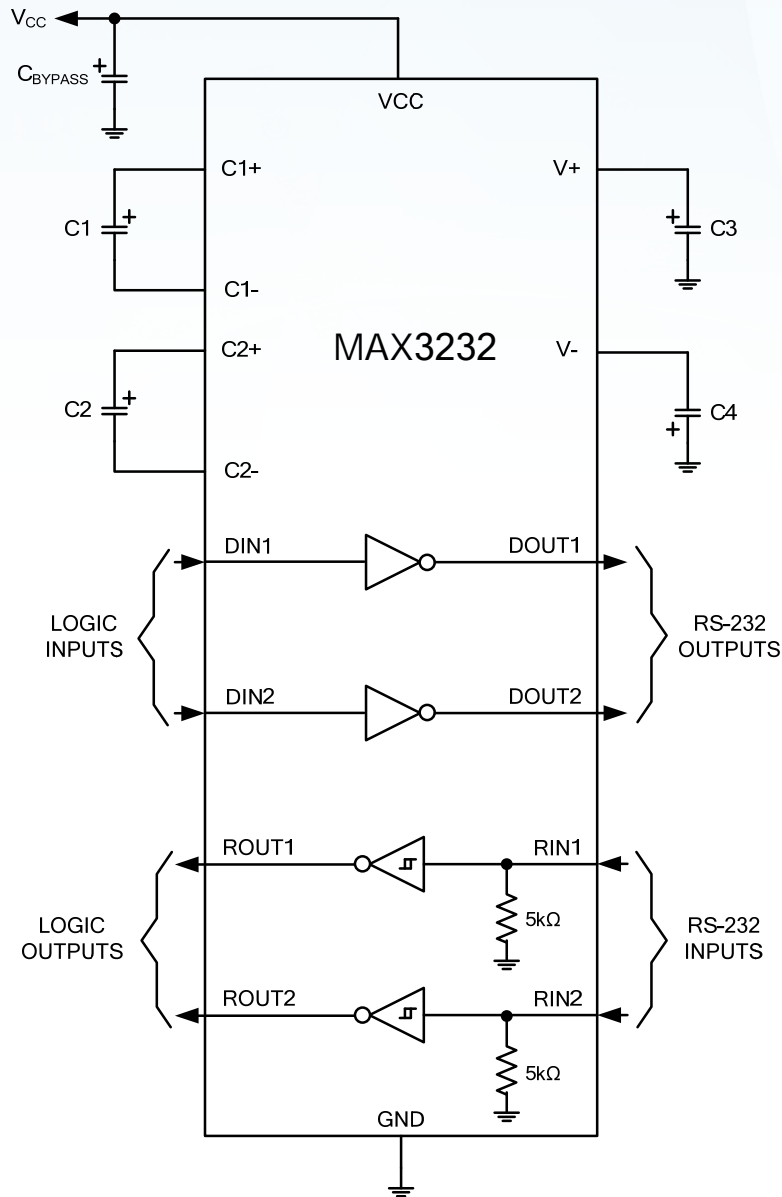

- Notes: 1. C3 can be connected to V_{CC} or GND.
 2. Resistor values shown are nominal.
 3. NC: No internal connection.
 4. Nonpolarized ceramic capacitors are acceptable. If polarized tantalum or electrolytic capacitors are used, they should be connected as shown.

Table1. Typical Operating Circuit and Capacitor Values

V _{CC} (V)	C1 (μF)	C2, C3, C4 (μF)	C _{BYPASS} (μF)
3.0~3.6	0.22	0.22	0.22
3.15~3.6	0.1	0.1	0.1
4.5~5.5	0.047	0.33	0.047
3.0~5.5	0.22	1.0	0.22

PACKAGE: SOP-16

UNIT: mm

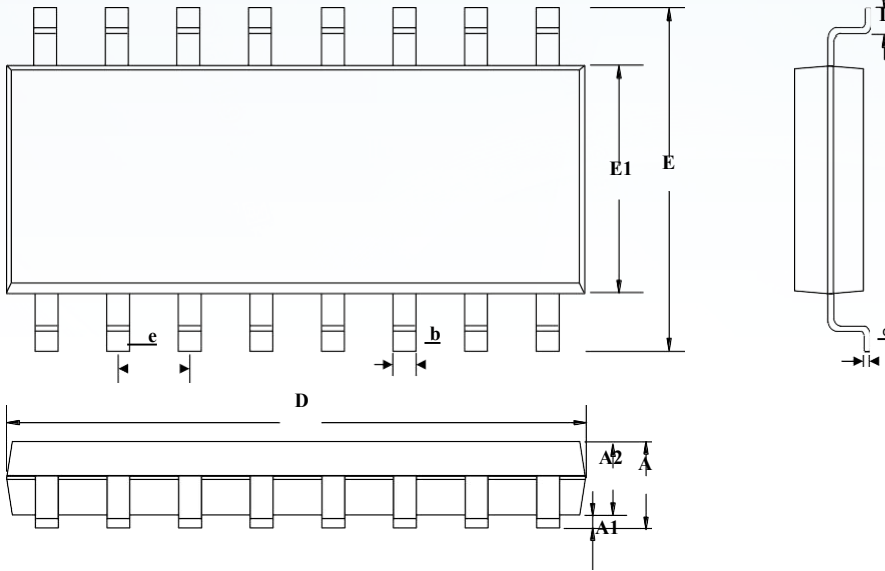

SYMBOL	MILLIMETER		
	MIN	NOM	MAX
A	—	—	1.80
A1	0.10	0.15	0.25
A2	1.25	1.45	1.65
b	0.33	—	0.51
c	0.17	—	0.25
D	9.50	—	10.20
E	5.80	6.00	6.20
E1	3.70	—	4.10
e	1.27BSC		
L	0.45	0.60	0.80

ORDERING INFORMATION

Ordering Number	Package	Baseqty	Packing
MAX3232CSE	SOP-16	2500	Tape and reel

Disclaimer

EVVOSEMI ("EVVO") reserves the right to make corrections, enhancements, improvements, and other changes to its products and services at any time, and to discontinue any product or service without notice.

EVVO warrants the performance of its hardware products to the specifications applicable at the time of sale in accordance with its standard warranty. Testing and other quality control techniques are used as deemed necessary by EVVO to support this warranty. Except where mandated by government requirements, testing of all parameters of each product is not necessarily performed.

Customers should obtain and confirm the latest product information and specifications before final design, purchase, or use. EVVO makes no warranty, representation, or guarantee regarding the suitability of its products for any particular purpose, nor does EVVO assume any liability for application assistance or customer product design. EVVO does not warrant or accept any liability for products that are purchased or used for any unintended or unauthorized application.

EVVO products are not authorized for use as critical components in life support devices or systems without the express written approval of EVVOSEMI.

The EVVO logo and EVVOSEMI are trademarks of EVVOSEMI or its subsidiaries in relevant jurisdictions. EVVO reserves the right to make changes without further notice to any products herein.