

EVVOSEMI[®]

THINK CHANGE DO



ESD



TVS



MOS



LDO



Diode



Sensor



DC-DC

Product Specification

▶ Domestic	Part Number	ZXMN6A25GTA
▶ Overseas	Part Number	ZXMN6A25GTA
▶ Equivalent	Part Number	ZXMN6A25GTA

EV is the abbreviation of name EVVO

60V N-Channel

Product Summary

- $V_{DS(V)} = 60V$
- $R_{DS(ON)} < 50m\ \Omega$ ($V_{GS} = 10V$)
- $R_{DS(ON)} < 70m\ \Omega$ ($V_{GS} = 4.5V$)

Description

This new generation MOSFET is designed to minimize the on-state resistance ($R_{DS(ON)}$) and yet maintain superior switching performance, making it ideal for high-efficiency power management applications.

Applications

- DC-DC Converters
- Power Management Functions
- Backlighting

Features and Benefits

- Low Input Capacitance
- Low On-Resistance
- Fast Switching Speed
- Lead-Free Finish;
- Halogen and Antimony Free.

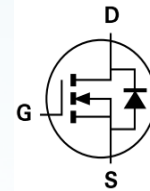

Equivalent Circuit

Maximum Ratings (@ $T_A = +25^\circ C$, unless otherwise specified.)

Characteristic			Symbol	Value	Units
Drain-Source Voltage			V_{DSS}	60	V
Gate-Source Voltage			V_{GSS}	± 20	V
Continuous Drain Current, $V_{GS} = 10V$	Steady State	$T_A = +25^\circ C$ (Note 6)	I_D	6.7	A
		$T_A = +70^\circ C$ (Note 6)		5.4	
		$T_A = +25^\circ C$ (Note 5)		4.8	
Maximum Body Diode Forward Current (Note 6)			I_S	5.7	A
Pulsed Drain Current (Note 7)			I_{DM}	28.5	A
Pulsed Source Current (Note 7)			I_{SM}	28.5	A

60V N-Channel

Thermal Characteristics (@T_A = +25°C, unless otherwise specified.)

Characteristic		Symbol	Value	Units
Total Power Dissipation Linear Derating Factor	T _A = +25°C (Note 5)	P _D	2 16	W mW/°C
	T _A = +25°C (Note 6)	P _D	3.9 31	W mW/°C
Thermal Resistance, Junction to Ambient	Steady state (Note 5)	R _{θJA}	62.5	°C/W
	Steady state (Note 6)		32	°C/W
Operating and Storage Temperature Range		T _J , T _{STG}	-55 to +150	°C

Electrical Characteristics (@T_A = +25°C, unless otherwise specified.)

Characteristic	Symbol	Min	Typ	Max	Unit	Test Condition
OFF CHARACTERISTICS (Note 9)						
Drain-Source Breakdown Voltage	BV _{DSS}	60			V	V _{GS} = 0V, I _D = 250μA
Zero Gate Voltage Drain Current	I _{DSS}			1.0	μA	V _{DS} = 60V, V _{GS} = 0V
Gate-Source Leakage	I _{GSS}			±100	nA	V _{GS} = ±20V, V _{DS} = 0V
ON CHARACTERISTICS (Note 9)						
Gate Threshold Voltage	V _{GS(th)}	1.0			V	V _{DS} = V _{GS} , I _D = 250μA
Static Drain-Source On-Resistance (Note 8)	R _{DS(on)}			50	mΩ	V _{GS} = 10V, I _D = 3.6A
				70		V _{GS} = 4.5V, I _D = 3.0A
Diode Forward Voltage (Note 8)	V _{SD}		0.85	0.95	V	V _{GS} = 0V, I _S = 5.5A
Forward Transconductance (Note 8 & 10)	g _{fs}		10.2		S	V _{DS} = 15V, I _D = 4.5A
DYNAMIC CHARACTERISTICS (Note 10)						
Input Capacitance	C _{iSS}		1,063		pF	V _{DS} = 30V, V _{GS} = 0V f = 1.0MHz
Output Capacitance	C _{oss}		104			
Reverse Transfer Capacitance	C _{rSS}		64			
Total Gate Charge (V _{GS} = 5.0V)	Q _g		11		nC	V _{DS} = 30V, I _D = 1.4A,
Total Gate Charge (V _{GS} = 10V)	Q _g		20.4			
Gate-Source Charge	Q _{gs}		4.1			
Gate-Drain Charge	Q _{gd}		5.1			
Turn-On Delay Time	t _{D(on)}		3.8		nS	V _{GS} = 10V, V _{DD} = 30V, R _G = 6.0Ω, I _D = 1.0A
Turn-On Rise Time	t _r		4.0			
Turn-Off Delay Time	t _{D(off)}		26.2			
Turn-Off Fall Time	t _f		10.6			
Body Diode Reverse Recovery Time	t _{rr}		22		nS	I _F = 2.2A, di/dt = 100A/μs
Body Diode Reverse Recovery Charge	Q _{rr}		21.4		nC	

- Notes:
- For a device surface mounted on 25mm x 25mm FR4 PCB with high coverage of single sided 1oz copper, in still air conditions
 - For a device surface mounted on FR4 PCB measured at t ≤ 10 secs.
 - Repetitive rating 25mm x 25mm FR4 PCB, D = 0.02, pulse width 300μs - pulse width limited by maximum junction temperature.
 - Measured under pulsed conditions. Width=300μs. Duty cycle ≤ 2%.
 - Short duration pulse test used to minimize self-heating effect.

Typical Characteristics

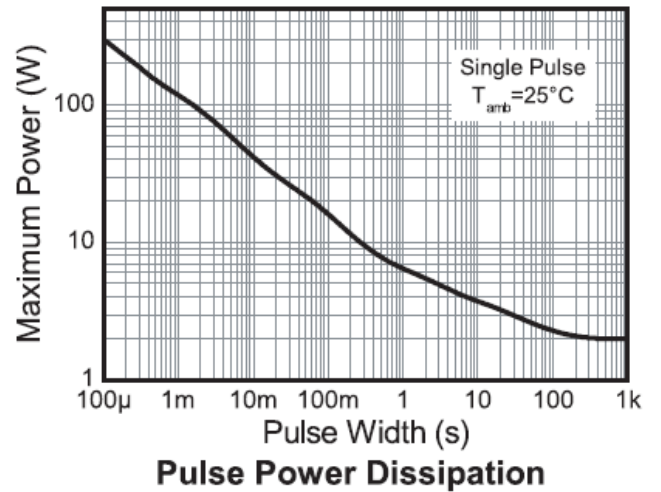
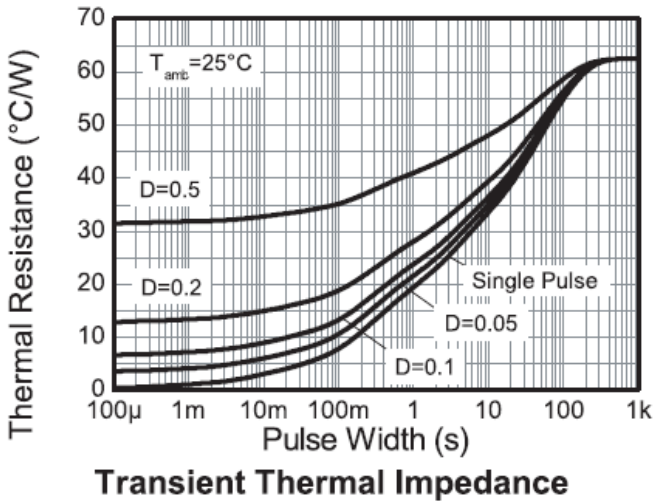
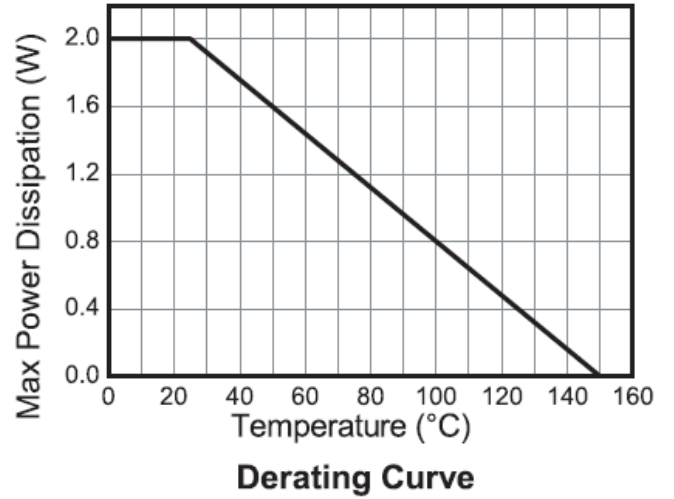
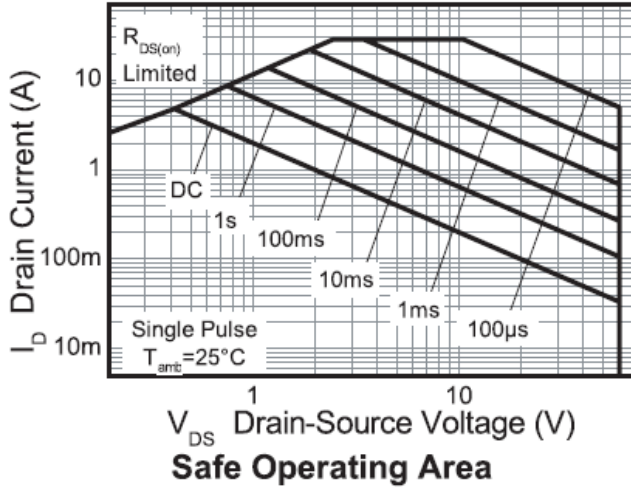

Typical Characteristics (continued)

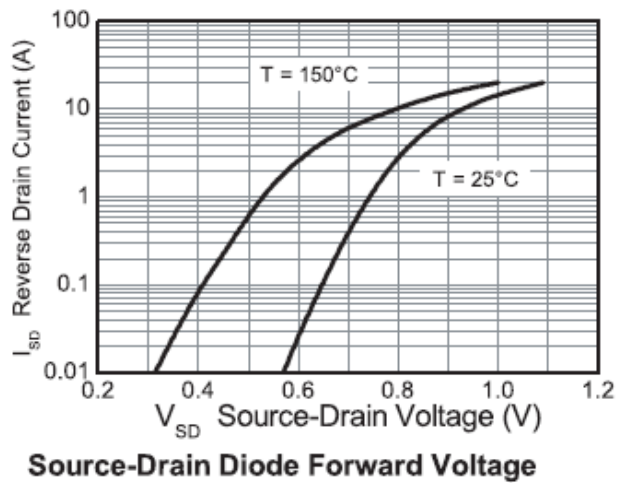
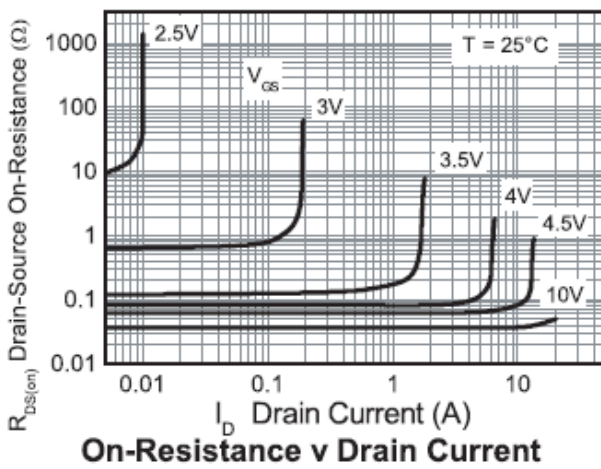
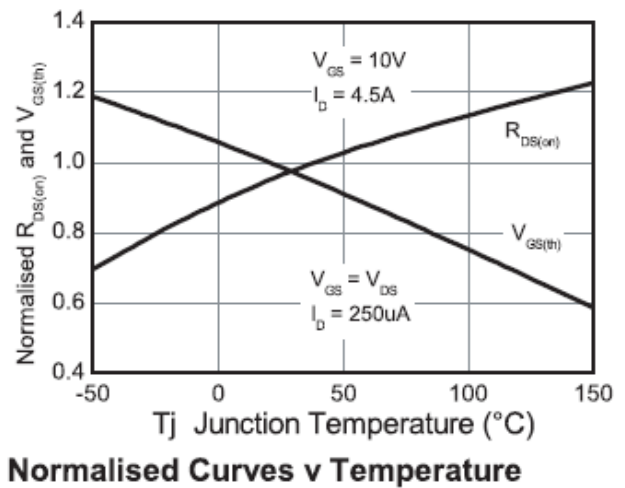
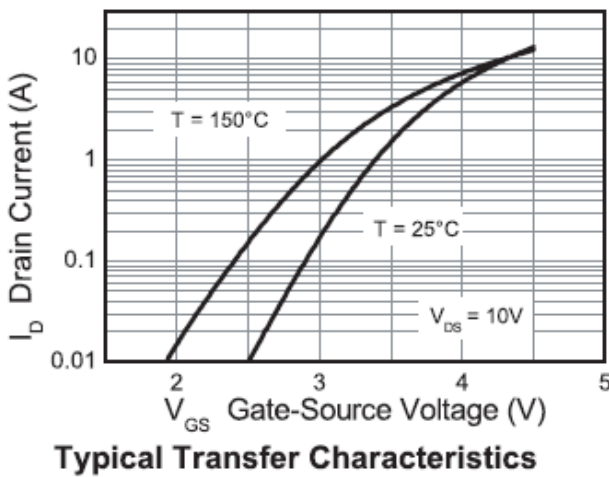
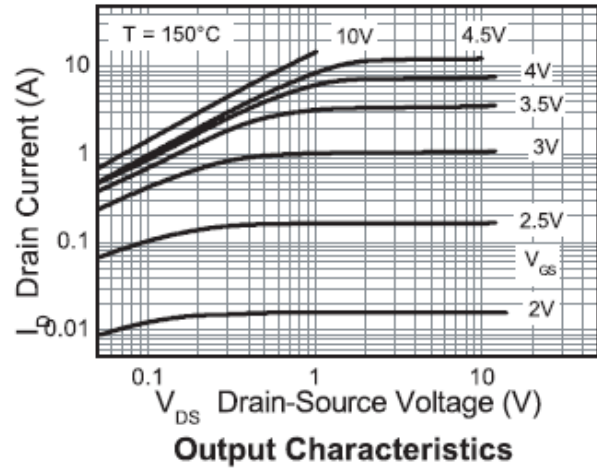
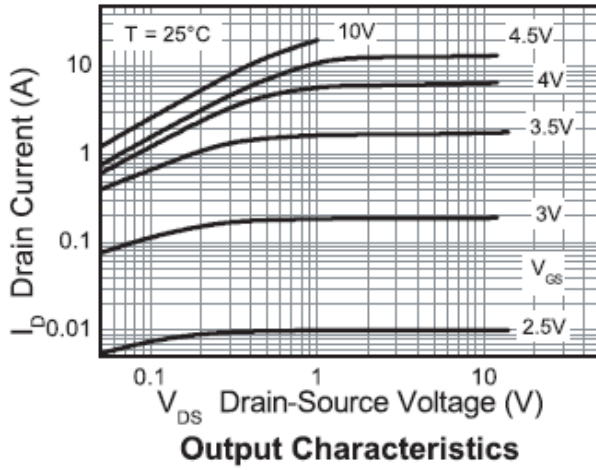

Typical Characteristics (cont.)

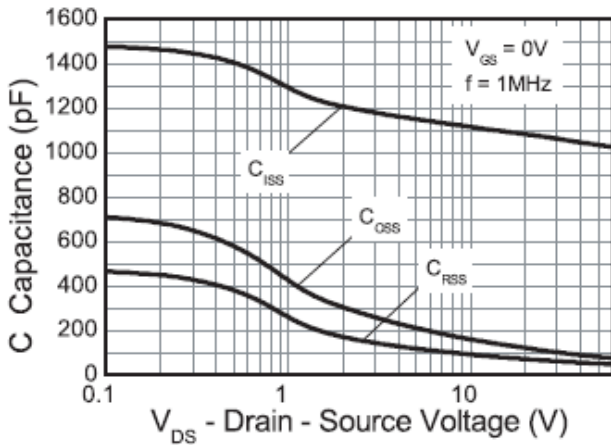

Capacitance v Drain-Source Voltage

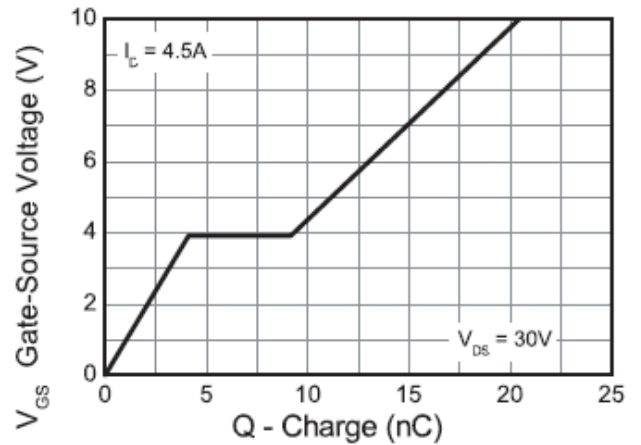

Gate-Source Voltage v Gate Charge

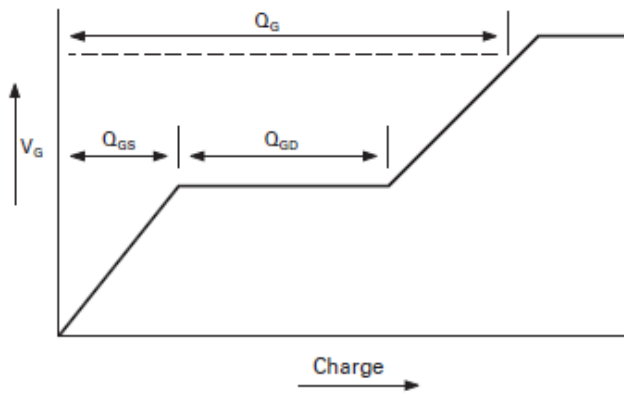

Basic gate charge waveform

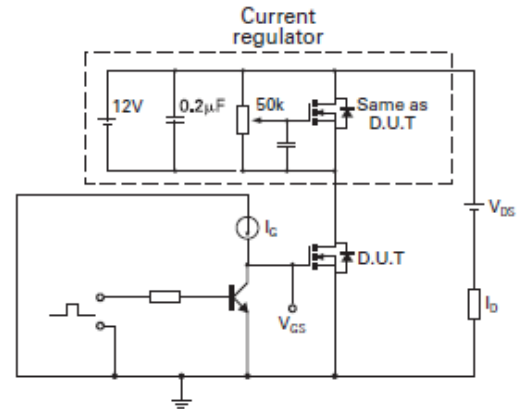

Gate charge test circuit

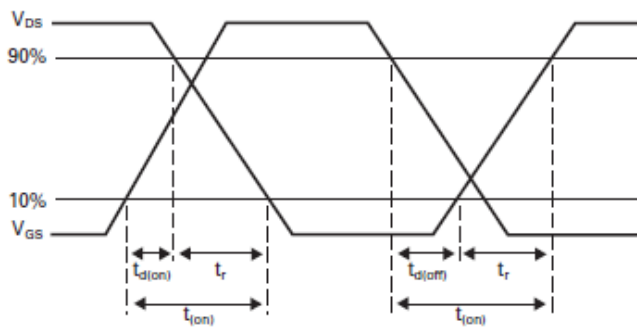

Switching time waveforms

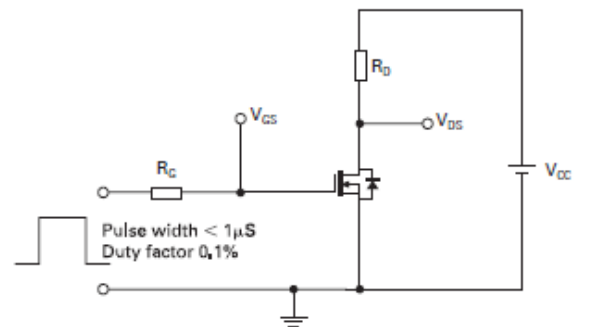

Switching time test circuit

SOT-223

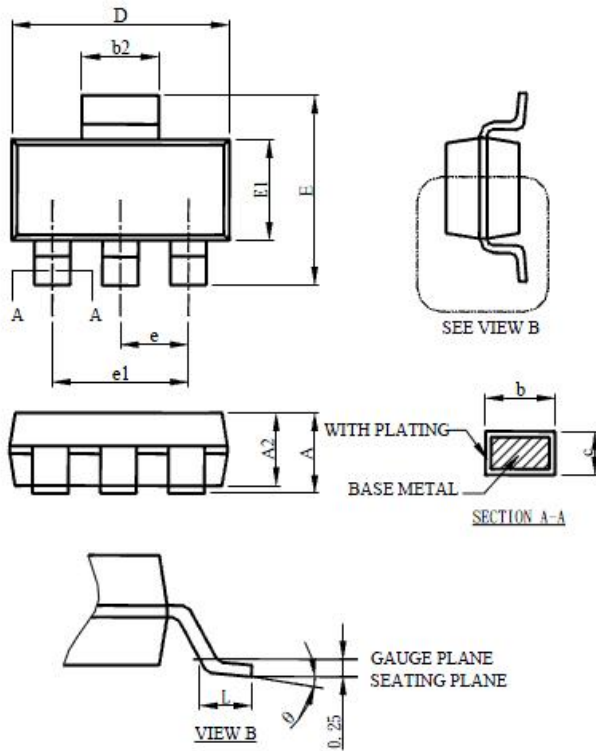

SYMBOL	SOT-223	
	MILLIMETERS	
	MIN.	MAX.
A		1.80
A1	0.02	0.10
A2	1.55	1.65
b	0.66	0.84
b2	2.90	3.10
c	0.23	0.33
D	6.30	6.70
E	6.70	7.30
E1	3.30	3.70
e	2.30 BSC	
e1	4.60 BSC	
L	0.90	
θ	0°	8°

Note:

1. Refer to JEDEC TO-261AA.
2. Dimension D and E1 are determined at the outermost extremes of the plastic body exclusive of mold flash, tie bar burrs, gate burrs, and interlead flash, but including any mismatch between the top and bottom of the plastic body.
3. Controlling dimension is millimeter, converted inch dimensions are not necessarily exact.

60V N-Channel

Marking

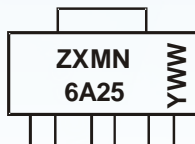

Ordering information

Order code	Package	Baseqty	Deliverymode
ZXMN6A25GTA	SOT-223	2500	Tape and reel

Disclaimer

EVVOSEMI ("EVVO") reserves the right to make corrections, enhancements, improvements, and other changes to its products and services at any time, and to discontinue any product or service without notice.

EVVO warrants the performance of its hardware products to the specifications applicable at the time of sale in accordance with its standard warranty. Testing and other quality control techniques are used as deemed necessary by EVVO to support this warranty. Except where mandated by government requirements, testing of all parameters of each product is not necessarily performed.

Customers should obtain and confirm the latest product information and specifications before final design, purchase, or use. EVVO makes no warranty, representation, or guarantee regarding the suitability of its products for any particular purpose, nor does EVVO assume any liability for application assistance or customer product design. EVVO does not warrant or accept any liability for products that are purchased or used for any unintended or unauthorized application.

EVVO products are not authorized for use as critical components in life support devices or systems without the express written approval of EVVOSEMI.

The EVVO logo and EVVOSEMI are trademarks of EVVOSEMI or its subsidiaries in relevant jurisdictions. EVVO reserves the right to make changes without further notice to any products herein.