

EVVOSEMI[®]

THINK CHANGE DO



ESD



TVS



MOS



LDO



Diode



Sensor



DC-DC

Product Specification

▶ Domestic	Part Number	1.5SMC SERIES
▶ Overseas	Part Number	1.5SMC SERIES
▶ Equivalent	Part Number	1.5SMC SERIES

EV is the abbreviation of name EVVO

SMCG Plastic-Encapsulate Diodes

1.5SMC SERIES Transient Voltage Suppressor Diodes

Features

- P_{PP} 1500W
- V_{RWM} 5.8V- 509V
- Glass passivated chip

Applications

- Clamping Voltage

Marking

- 1.5SMCXXCA/XXA
XX : From 6.8 To 600

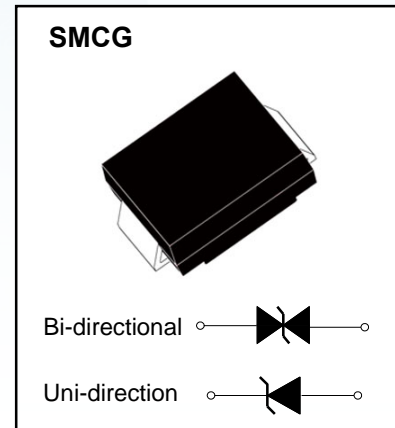

Limiting Values (Absolute Maximum Rating)

Item	Symbol	Unit	Conditions	Max
Peak pulse power dissipation	P _{PPM}	W	with a 10/1000us waveform	1500
Peak pulse current (1)	I _{PPM}	A	with a 10/1000us waveform	See Next Table
Power dissipation	P _D	W	On infinite heat sink at T _L =75°C	5.0
Peak forward surge current(2)	I _{FSM}	A	8.3 ms single half sine-wave unidirectional only	200
Operating junction and storage temperature range	T _J , T _{STG}	°C		-55 to +150

Electrical Characteristics (T_a=25°C Unless otherwise specified)

Item	Symbol	Unit	Conditions	Max
Maximum instantaneous forward Voltage (3)	V _F	V	at 100A for unidirectional only	3.5/6.5
Thermal resistance	R _{θJL}	°C/W	junction to lead	15
	R _{θJA}	°C/W	junction to ambient, L _{Lead} = 10 mm	75

Notes:

- (1) Non-repetitive current pulse, per Fig. 3 and derated above T_A = 25°C per Fig.2.
- (2) Mounted on 0.2 x 0.2" (5.0 x 5.0 mm) copper pads to each terminal
- (3) V_F<3.5V for devices of V_{BR}<200V and V_F<5.0V for devices of V_{BR}>201V

Electrical Characteristics ($T_A=25^{\circ}\text{C}$ unless otherwise noted)

Part Number		Reverse Stand-off Voltage	Breakdown Voltage $V_{BR} @ I_T$		Test Current	Max. Clamping Voltage @ I_{PP}	Max. Peak Pulse Current	Max. Reverse Leakage @ V_{RWM}
UNI-POLAR	BI-POLAR	$V_{RWM}(V)$	Min.(V)	Max.(V)	$I_T(mA)$	$V_{C MAX.}(V)$	$I_{PP}(A)$	$I_R(\mu A)$
1.5SMC6.8A	1.5SMC6.8CA	5.8	6.45	7.14	10	10.5	144.80	1000
1.5SMC7.5A	1.5SMC7.5CA	6.4	7.13	7.88	10	11.3	134.50	500
1.5SMC8.2A	1.5SMC8.2CA	7.0	7.79	8.61	10	12.1	125.60	200
1.5SMC9.1A	1.5SMC9.1CA	7.8	8.65	9.55	1	13.4	113.40	50
1.5SMC10A	1.5SMC10CA	8.6	9.50	10.50	1	14.5	104.80	10
1.5SMC11A	1.5SMC11CA	9.4	10.50	11.60	1	15.6	97.40	5
1.5SMC12A	1.5SMC12CA	10.2	11.40	12.60	1	16.7	91.00	5
1.5SMC13A	1.5SMC13CA	11.1	12.40	13.70	1	18.2	83.50	1
1.5SMC15A	1.5SMC15CA	12.8	14.30	15.80	1	21.2	71.70	1
1.5SMC16A	1.5SMC16CA	13.6	15.20	16.80	1	22.5	67.60	1
1.5SMC18A	1.5SMC18CA	15.3	17.10	18.90	1	25.5	60.30	1
1.5SMC20A	1.5SMC20CA	17.1	19.00	21.00	1	27.7	54.90	1
1.5SMC22A	1.5SMC22CA	18.8	20.90	23.10	1	30.6	49.70	1
1.5SMC24A	1.5SMC24CA	20.5	22.80	25.20	1	33.2	45.80	1
1.5SMC27A	1.5SMC27CA	23.1	25.70	28.40	1	37.5	40.50	1
1.5SMC30A	1.5SMC30CA	25.6	28.50	31.50	1	41.4	36.70	1
1.5SMC33A	1.5SMC33CA	28.2	31.40	34.70	1	45.7	33.30	1
1.5SMC36A	1.5SMC36CA	30.8	34.20	37.80	1	49.9	30.50	1
1.5SMC39A	1.5SMC39CA	33.3	37.10	41.00	1	53.9	28.20	1
1.5SMC43A	1.5SMC43CA	36.8	40.90	45.20	1	59.3	25.60	1
1.5SMC47A	1.5SMC47CA	40.2	44.70	49.40	1	64.8	23.50	1
1.5SMC51A	1.5SMC51CA	43.6	48.50	53.60	1	70.1	21.70	1
1.5SMC56A	1.5SMC56CA	47.8	53.20	58.80	1	77.0	19.70	1
1.5SMC62A	1.5SMC62CA	53.0	58.90	65.10	1	85.0	17.90	1
1.5SMC68A	1.5SMC68CA	58.1	64.60	71.40	1	92.0	16.50	1
1.5SMC75A	1.5SMC75CA	64.1	71.30	78.80	1	103.0	14.80	1
1.5SMC82A	1.5SMC82CA	70.1	77.90	86.10	1	113.0	13.50	1
1.5SMC91A	1.5SMC91CA	77.8	86.50	95.50	1	125.0	12.20	1
1.5SMC100A	1.5SMC100CA	85.5	95.00	105.00	1	137.0	11.10	1
1.5SMC110A	1.5SMC110CA	94.0	105.0	116.0	1	152.0	10.00	1
1.5SMC120A	1.5SMC120CA	102.0	114.0	126.0	1	165.0	9.20	1
1.5SMC130A	1.5SMC130CA	111.0	124.0	137.0	1	179.0	8.50	1
1.5SMC150A	1.5SMC150CA	128.0	143.0	158.0	1	207.0	7.30	1
1.5SMC160A	1.5SMC160CA	136.0	152.0	168.0	1	219.0	6.90	1
1.5SMC170A	1.5SMC170CA	145.0	162.0	179.0	1	234.0	6.50	1
1.5SMC180A	1.5SMC180CA	154.0	171.0	189.0	1	246.0	6.20	1
1.5SMC200A	1.5SMC200CA	171.0	190.0	210.0	1	274.0	5.50	1
1.5SMC220A	1.5SMC220CA	185.0	209.0	231.0	1	328.0	4.60	1
1.5SMC250A	1.5SMC250CA	214.0	237.0	263.0	1	344.0	4.40	1
1.5SMC300A	1.5SMC300CA	256.0	285.0	315.0	1	414.0	3.70	1
1.5SMC350A	1.5SMC350CA	300.0	332.0	368.0	1	482.0	3.20	1
1.5SMC400A	1.5SMC400CA	342.0	380.0	420.0	1	548.0	2.80	1
1.5SMC440A	1.5SMC440CA	376.0	418.0	462.0	1	602.0	2.50	1
1.5SMC480A	1.5SMC480CA	408.0	456.0	504.0	1	658.0	2.30	1
1.5SMC510A	1.5SMC510CA	434.0	485.0	535.0	1	698.0	2.10	1
1.5SMC530A	1.5SMC530CA	450.0	503.0	556.0	1	725.0	2.10	1
1.5SMC540A	1.5SMC540CA	459.0	513.0	567.0	1	740.0	2.00	1
1.5SMC550A	1.5SMC550CA	467.0	522.5	577.5	1	760.0	2.00	1
1.5SMC600A	1.5SMC600CA	509.0	570.0	630.0	1	820.0	1.80	1

Typical Characteristics

FIG1: Peak Pulse Power Rating Curve

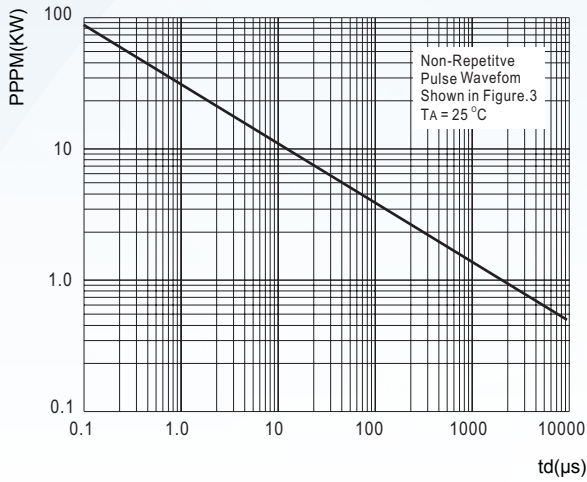

FIG2: Pulse Power or Current vs. Initial Junction Temperature

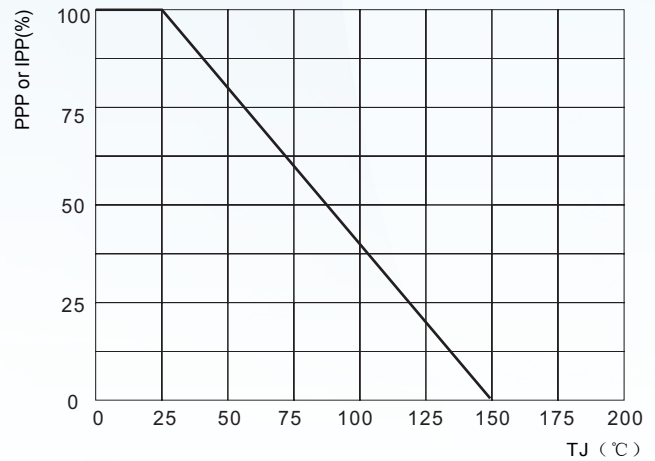

FIG3: Pulse Waveform

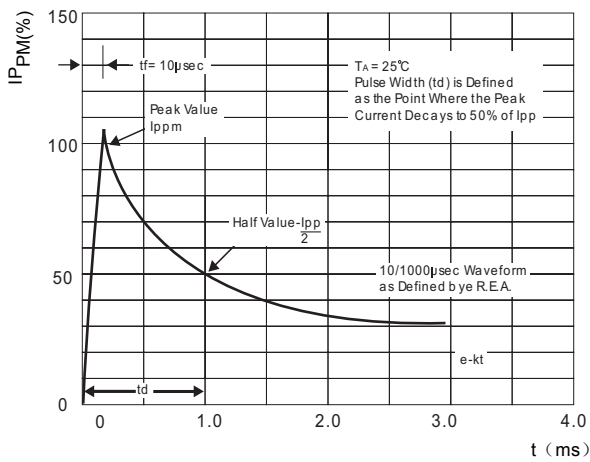

FIG4: Typical Transient Thermal Impedance

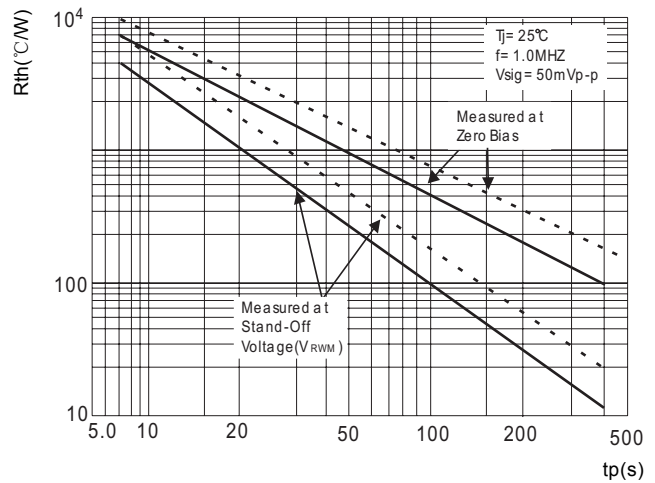

FIG5: Maximum Non-Repetitive Surge Current

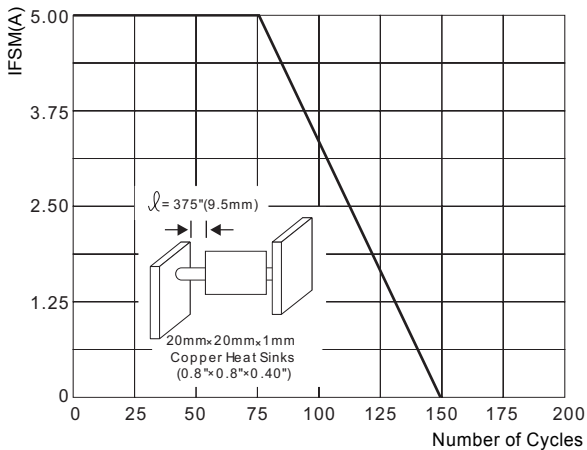
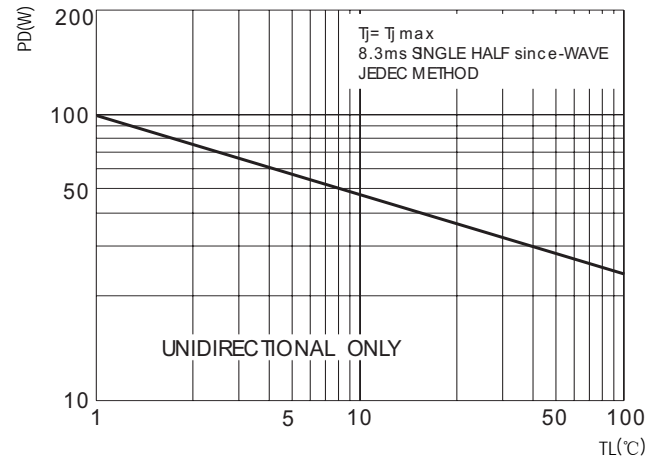
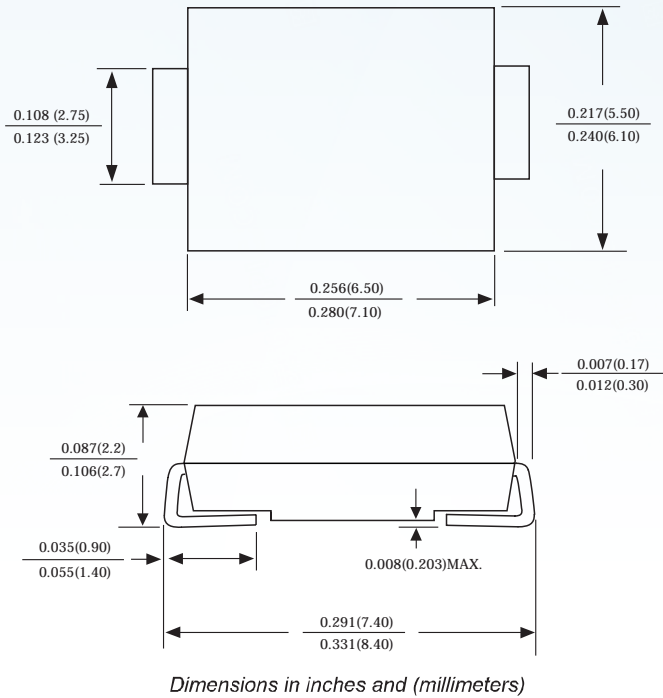

FIG6: Steady State Power Dissipation



SMCG Package Outline Dimensions



SMCG Suggested Pad Layout

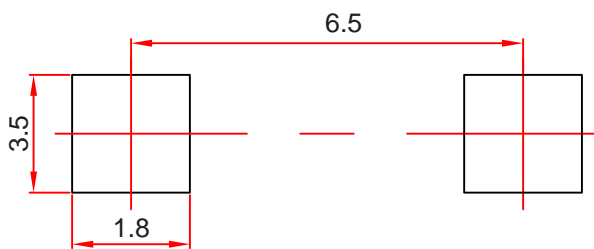

Note:

1. Controlling dimension: in millimeters.
2. General tolerance: ± 0.05 mm.
3. The pad layout is for reference purposes only.

NOTICE

Kefan reserves the right to make modifications, enhancements, improvements, corrections or other changes without further notice to any product herein. Kefan does not assume any liability arising out of the application or use of any product described herein.

Reel Taping Specifications For Surface Mount Devices- SMCG

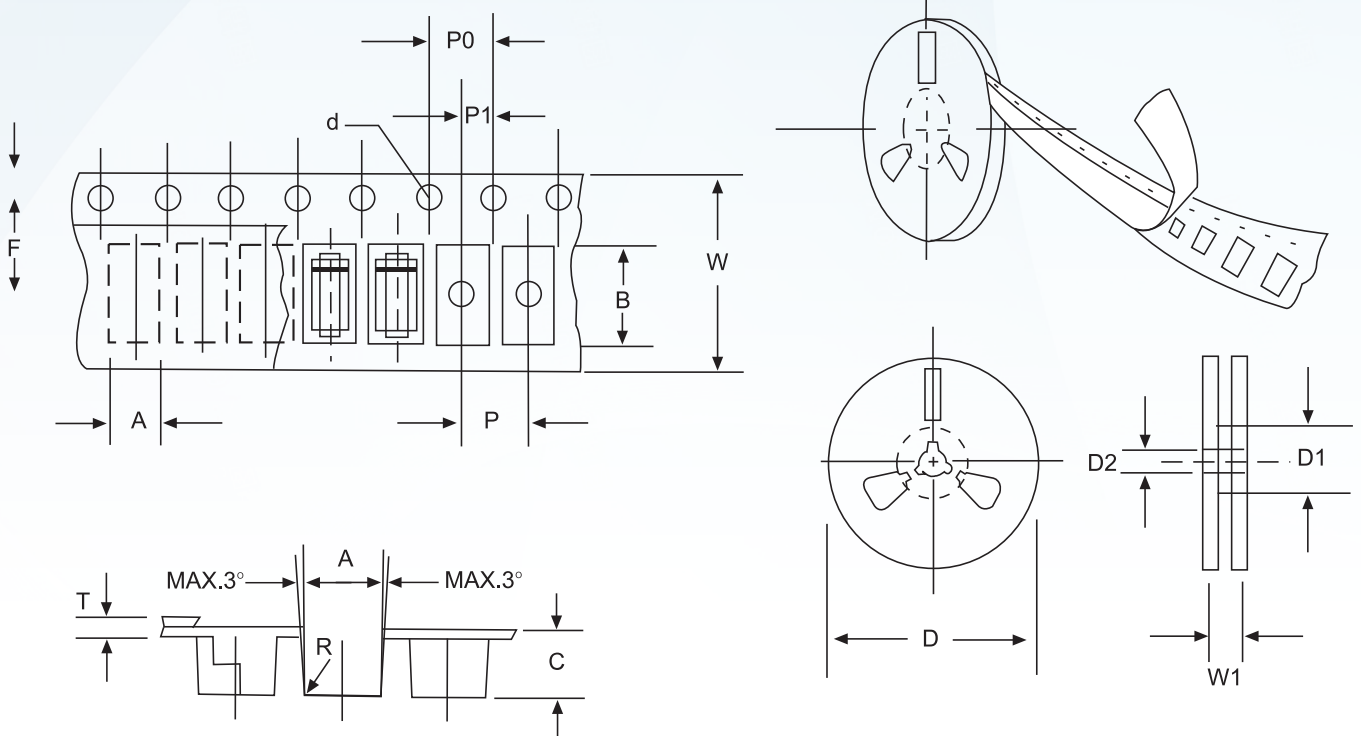

FIG:CONFIGURATION OF SURFACE MOUNTED DEVICES TAPING

ITEM	SYMBOL	SMCG mm(inch)
Carrier width	A	6.05±0.1(0.238±0.004)
Carrier length	B	8.31±0.1(0.327±0.004)
Carrier depth	C	2.70±0.1(0.106±0.004)
Sprocket hole	d	1.55±0.05(0.061±0.002)
Reel outside diameter	D	330±2.0(13±0.079)
Reel inner diameter	D1	75 ±1.0 (2.95 ±0.039)
Feed hole diameter	D2	13±0.5(0.512±0.020)
Strocket hole position	E	1.75±0.1(0.069±0.004)
Punch hole position	F	7.65±0.05(0.301±0.002)
Punch hole pitch	P	8.0±0.1(0.315±0.004)
Sprocket hole pitch	P0	4.0±0.1(0.157±0.004)
Embossment center	P1	2.0±0.1(0.079±0.004)
Totall tape thickness	T	0.3±0.1(0.012±0.004)
Tape width	W	16.0±0.2(0.630±0.008)
Reel width	W1	24.0±2.0(0.945±0.079)

NOTE:Devices are packed in accordance with EIA standard RS-481-A and specification given above.

Disclaimer

EVVOSEMI ("EVVO") reserves the right to make corrections, enhancements, improvements, and other changes to its products and services at any time, and to discontinue any product or service without notice.

EVVO warrants the performance of its hardware products to the specifications applicable at the time of sale in accordance with its standard warranty. Testing and other quality control techniques are used as deemed necessary by EVVO to support this warranty. Except where mandated by government requirements, testing of all parameters of each product is not necessarily performed.

Customers should obtain and confirm the latest product information and specifications before final design, purchase, or use. EVVO makes no warranty, representation, or guarantee regarding the suitability of its products for any particular purpose, nor does EVVO assume any liability for application assistance or customer product design. EVVO does not warrant or accept any liability for products that are purchased or used for any unintended or unauthorized application.

EVVO products are not authorized for use as critical components in life support devices or systems without the express written approval of EVVOSEMI.

The EVVO logo and EVVOSEMI are trademarks of EVVOSEMI or its subsidiaries in relevant jurisdictions. EVVO reserves the right to make changes without further notice to any products herein.