

# EVVOSEMI<sup>®</sup>

THINK CHANGE DO



ESD



TVS



MOS

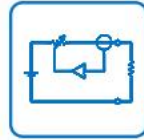

LDO

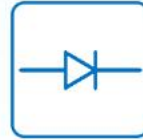

Diode



Sensor



DC-DC

## Product Specification

▶ Domestic	Part Number	SN74LVC1G07
▶ Overseas	Part Number	SN74LVC1G07
▶ Equivalent	Part Number	SN74LVC1G07

EV is the abbreviation of name EVVO

## General Description

The SN74LVC1G07 is a high performance single non-inverting buffer with open drain outputs operating from a 1.65 to 5.5V supply. The Output stage is open drain with Over Voltage Tolerance. This allows the SN74LVC1G07 to be used to interface 5.0V circuits to circuits of any voltage between 0 and +7.0V.

## Features

- Tiny SC70-5, SOT23-5 and DFN6-1.0mm\*1.5mm Packages
- Designed for 1.65V to 5.5V V<sub>CC</sub> Operation
- 24 mA Output Sink Capability, Pullup may be between 0 and 7.0V
- Near Zero Static Supply Current Substantially Reduces System Power Requirements
- These Devices are Pb-Free and RoHS Compliant

## Pin Configuration

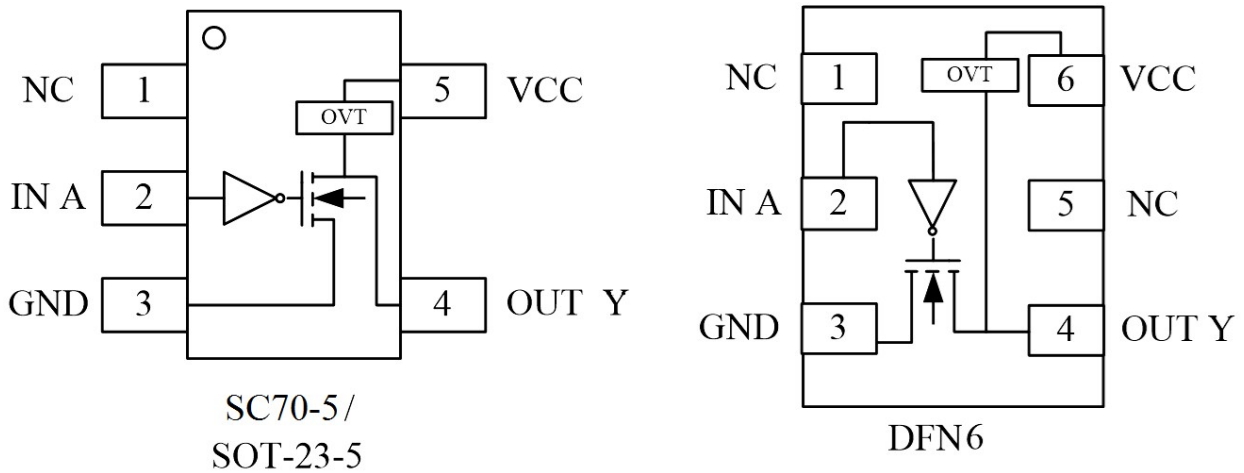

Figure1, Top View

## Pin Function

(SC70-5/ SOT23-5)

PIN	FUNCTION
1	NC
2	IN A
3	GND
4	OUT
5	VCC

(DFN6)

PIN	FUNCTION
1	NC
2	IN A
3	GND
4	OUT
5	NC
6	VCC

## Block Diagram

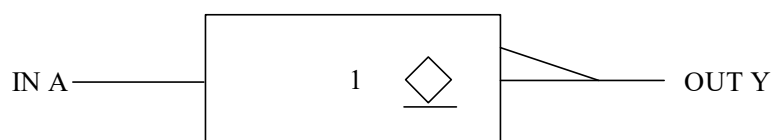

Figure 2. Logic Symbol

## Functional Description

### Function Table

Input	Output
A	Y
L	L
H	Z

## Absolute Maximum Ratings

Symbol	Parameter	Value	Unit
V <sub>CC</sub>	DC Supply Voltage	-0.5 to 7.0	V
V <sub>I</sub>	DC Input Voltage	-0.5 ≤ V <sub>I</sub> ≤ +7.0	V
V <sub>O</sub>	DC Output Voltage Output in Higher or Low State (Note 1)	-0.5 to V <sub>CC</sub> + 0.5	V
I <sub>IK</sub>	DC Input Diode Current V <sub>I</sub> < GND	-50	mA
I <sub>OK</sub>	DC Output Diode Current V <sub>O</sub> < GND, V <sub>O</sub> > V <sub>CC</sub>	±50	mA
I <sub>O</sub>	DC Output Sink Current	±50	mA
I <sub>CC</sub>	DC Supply Current per Supply Pin	±100	mA
I <sub>GND</sub>	DC Ground Current per Supply Pin	±100	mA
T <sub>STG</sub>	Storage Temperature Range	-65 to 150	°C
T <sub>L</sub>	Lead Temperature, 1 mm from Case for 10 Seconds	260	°C
T <sub>J</sub>	Junction Temperature Under Bias	150	°C
θ <sub>JA</sub>	Thermal Resistance SC70-6	333	°C/W
	SOT23-6	225	
	DFN6	423	
P <sub>D</sub>	Power Dissipation in Still Air at 85°C	200	mW
MSL	Moisture Sensitivity	Level 1	
ESD	ESD Classification Human Body Model (Note 2)	2000	V
	Machine Model (Note3)	200	
	Charged Device Model (Note 4)	N/A	
I <sub>Latchup</sub>	Latchup Performance Above V <sub>CC</sub> and Below GND at 125°C (Note 5)	±100	mA

Stresses exceeding those listed in the Maximum Ratings table may damage the device. If any of these limits are exceeded, device functionality should not be assumed, damage may occur and reliability may be affected.

1. IO absolute maximum rating must be observed.
2. Tested to EIA/JESD22-A114-A, rated to EIA/JESD22-A114-B.
3. Tested to EIA/JESD22-A115-A, rated to EIA/JESD22-A115-A.
4. Tested to JESD22-C101-A.
5. Tested to EIA/JESD78.

## Recommended Operating Conditions

Symbol	Parameter	Min	Max	Unit
V <sub>CC</sub>	DC Supply Voltage Operating	1.65	5.5	V
	Date Retention	1.5	5.5	
V <sub>IN</sub>	DC Input Voltage	0	5.5	V
V <sub>OUT</sub>	DC Output Voltage (High or Low State)	0	5.5	V
T <sub>A</sub>	Operating Temperature Range	-40	85	°C
t <sub>r</sub> , t <sub>f</sub>	Input Rise and Fall Time V <sub>CC</sub> = 2.5 V ± 0.2 V	0	20	ns/V
	V <sub>CC</sub> = 3.0 V ± 0.3 V	0	10	
	V <sub>CC</sub> = 5.0 V ± 0.5 V	0	5	

Functional operation above the stresses listed in the Recommended Operating Ranges is not implied.

## Electrical Characteristics

### DC ELECTRICAL CHARACTERISTICS

Symbol	Parameter	Condition	VCC(V)	TA = 25 °C			-40°C ≤TA≤85°C		Unit
				Min	Typ	Max	Min	Max	
V <sub>IH</sub>	High-Level Input Voltage		1.65to1.95 2.3 to 5.5	0.75V <sub>cc</sub> 0.7V <sub>cc</sub>			0.75V <sub>cc</sub> 0.7V <sub>cc</sub>		V
V <sub>IL</sub>	Low-Level Input Voltage		1.65to1.95 2.3 to 5.5			0.25V <sub>cc</sub> 0.3V <sub>cc</sub>		0.25V <sub>cc</sub> 0.3V <sub>cc</sub>	V
V <sub>OL</sub>	Low-Level Output Voltage V <sub>IN</sub> = V <sub>IL</sub>	I <sub>OL</sub> =100uA	1.65to5.5		0.0	0.1		0.1	V
		I <sub>OL</sub> =3mA	1.65		0.08	0.24		0.24	
		I <sub>OL</sub> =8mA	2.3		0.20	0.3		0.3	
		I <sub>OL</sub> =12mA	2.7		0.22	0.4		0.4	
		I <sub>OL</sub> =16mA	3.0		0.28	0.4		0.4	
		I <sub>OL</sub> =24mA	3.0		0.38	0.55		0.55	
		I <sub>OL</sub> =32mA	4.5		0.42	0.55		0.55	
I <sub>IN</sub>	Input Leakage Current	V <sub>IN</sub> = 5.5 V or GND	0 to 5.5			±0.1		±1.0	uA
I <sub>OFF</sub>	Power Off Leakage Current	V <sub>IN</sub> = 5.5 V or V <sub>OUT</sub> = 5.5 V	0			1		10	uA
I <sub>CC</sub>	Quiescent Supply Current	V <sub>IN</sub> = 5.5 V or GND	5.5			1		10	uA

Product parametric performance is indicated in the Electrical Characteristics for the listed test conditions, unless otherwise noted. Product performance may not be indicated by the Electrical Characteristics if operated under different conditions.

### AC ELECTRICAL CHARACTERISTICS tr=tf= 2.5ns;

Symbol	Parameter	Condition	Vcc(V)	TA = 25 °C			-40°C ≤TA≤85°C		Unit
				Min	Typ	Max	Min	Max	
t <sub>PZL</sub>	Propagation Delay (Figure3and4)	R <sub>L</sub> = 500Ω C <sub>L</sub> = 15 pF	1.8	2.0	9.1	11.1	2.0	12.8	ns
			2.5	1.5	6.1	7.5	1.5	8.5	
			3.3	1.2	4.9	6.0	1.5	6.9	
			5.0	0.8	3.9	4.9	0.8	5.5	
t <sub>PLZ</sub>	Propagation Delay (Figure3and4)	R <sub>L</sub> = 500Ω C <sub>L</sub> = 15 pF	1.8	2.0	9.1	11.1	2.0	12.8	ns
			2.5	1.5	5.9	7.3	1.5	8.3	
			3.3	1.2	3.9	4.9	1.5	5.5	
			5.0	0.8	3.0	3.7	0.8	4.2	

### CAPACITIVE CHARACTERISTICS

Symbol	Parameter	Condition	Typical	Unit
$C_{IN}$	Input Capacitance	$V_{CC} = 5.5 \text{ V}, V_I = 0 \text{ V or } V_{CC}$	>2.5	pF
$C_{PD}$	Power Dissipation Capacitance (Note 6)	10 MHz, $V_{CC} = 3.3 \text{ V}, V_I = 0 \text{ V or } V_{CC}$	26	pF
		10 MHz, $V_{CC} = 5.5 \text{ V}, V_I = 0 \text{ V or } V_{CC}$	30	

6.  $C_{PD}$  is defined as the value of the internal equivalent capacitance which is calculated from the operating current consumption without load. Average operating current can be obtained by the equation:

$ICC(OPR) = CPD * V_{CC} * f_{in} + ICC * CPD$  is used to determine the no-load dynamic power consumption;

$PD = CPD * V_{CC}^2 * f_{in} + ICC * V_{CC} * Fig.$

Package Dimension

SC70-5

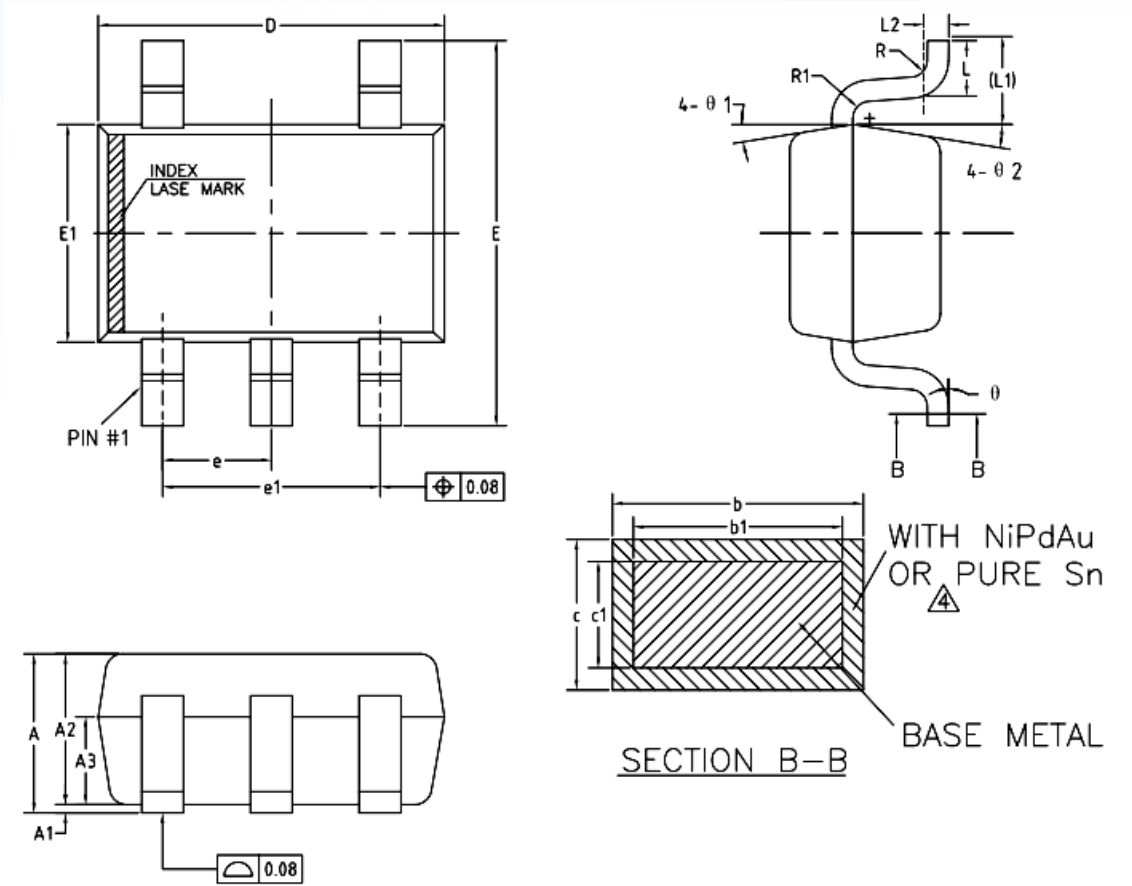

COMMON DIMENSIONS  
(UNITS OF MEASURE=MILLIMETER)

SYMBOL	MIN	NOM	MAX
A	0.85	—	1.05
A1	0	—	0.10
A2	0.80	0.90	1.00
A3	0.47	0.52	0.57
b	NiPdAu 0.22	—	0.29
	PURE Sn 0.23	—	0.33
b1	0.22	0.25	0.28
c	NiPdAu 0.115	—	0.15
	PURE Sn 0.12	—	0.18
c1	0.115	0.13	0.14
D	2.02	2.07	2.12
E	2.20	2.30	2.40
E1	1.25	1.30	1.35
e	0.60	0.65	0.70
e1	1.20	1.30	1.40
L	0.28	0.33	0.38
L1	0.50REF		
L2	0.15BSC		
R	0.10	—	—
R1	0.10	—	0.25
θ	0°	—	8°
θ 1	6°	9°	12°
θ 2	6°	9°	12°

SOT23-5

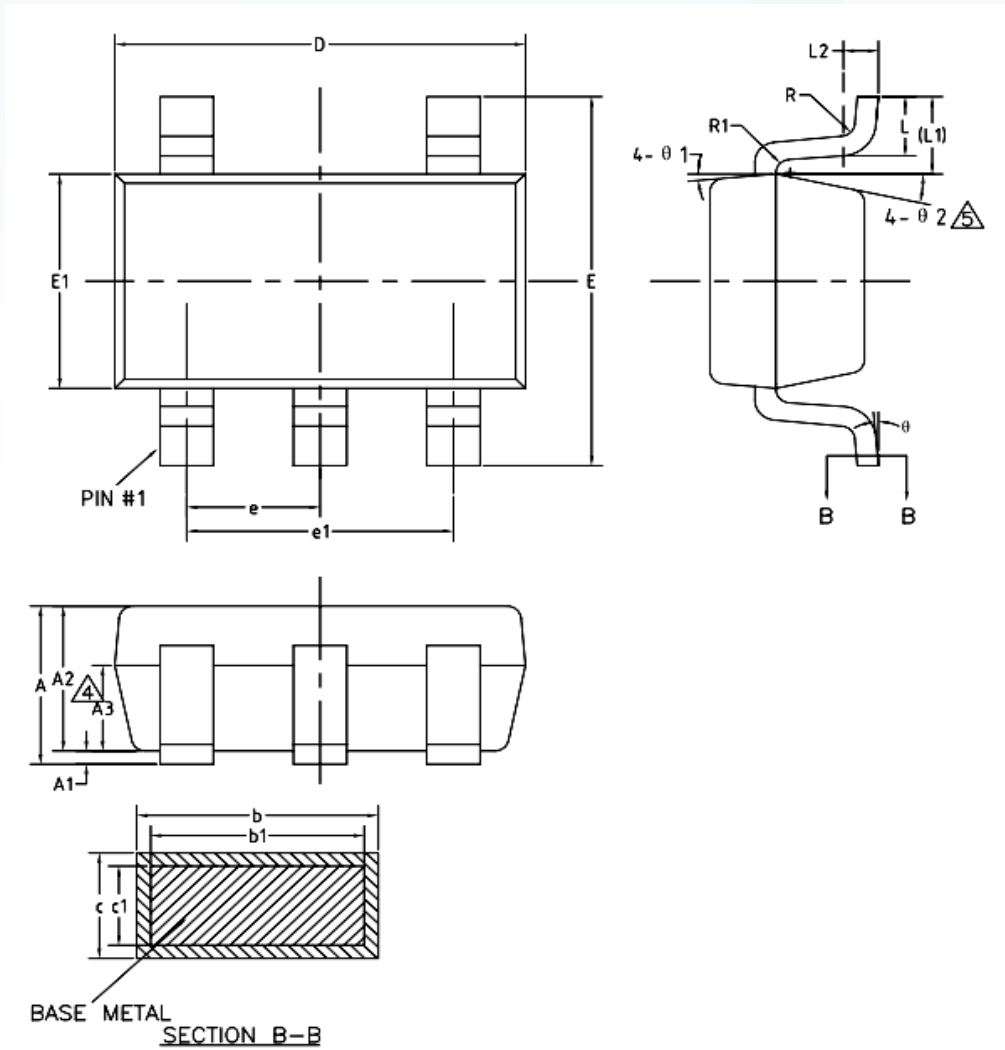

COMMON DIMENSIONS  
(UNITS OF MEASURE=MILLIMETER)

SYMBOL	MIN	NOM	MAX
A	—	—	1.25
A1	0	—	0.15
A2	1.00	1.10	1.20
A3	0.60	0.65	0.70
b	0.36	—	0.50
b1	0.36	0.38	0.45
c	0.14	—	0.20
c1	0.14	0.15	0.16
D	2.826	2.926	3.026
E	2.60	2.80	3.00
E1	1.526	1.626	1.726
e	0.90	0.95	1.00
e1	1.80	1.90	2.00
L	0.35	0.45	0.60
L1	0.59REF		
L2	0.25BSC		
R	0.10	—	—
R1	0.10	—	0.25
$\theta$	0°	—	8°
$\theta 1$	3°	5°	7°
$\theta 2$	6°	—	14°



DFN6

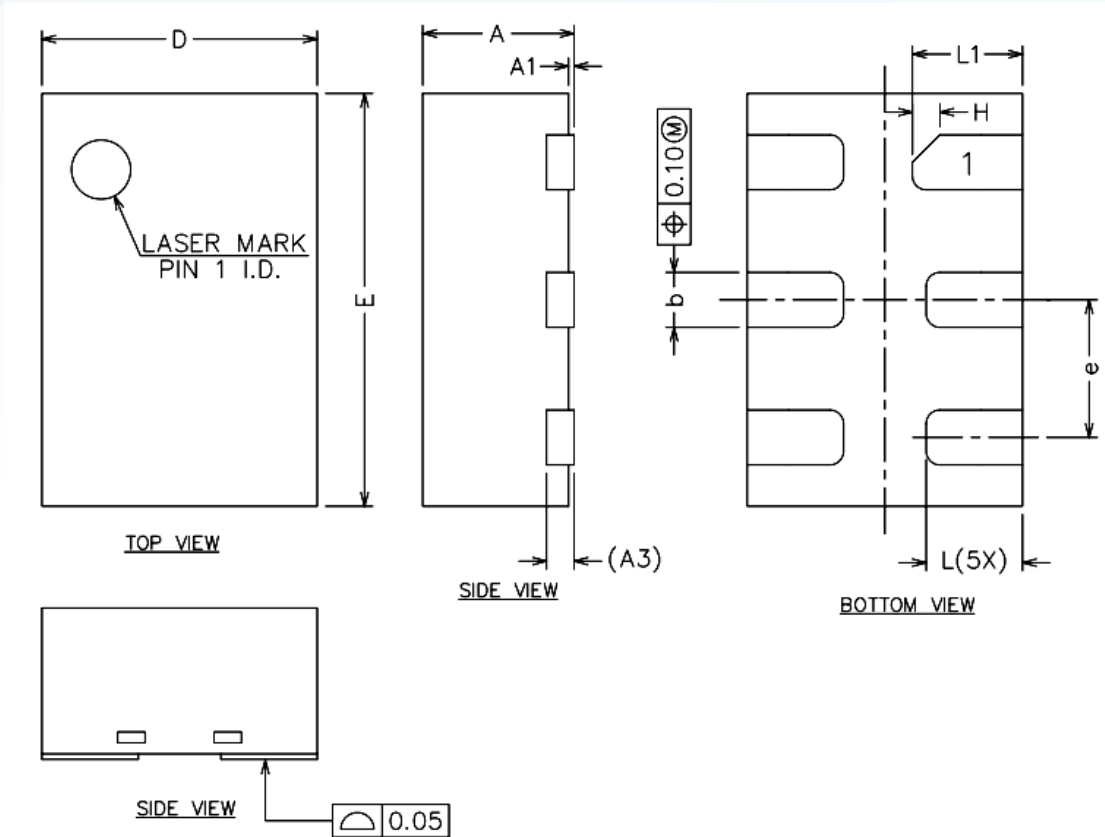

COMMON DIMENSIONS  
(UNITS OF MEASURE=MILLIMETER)

SYMBOL	MIN	NOM	MAX
A	0.50	—	0.60
A1	0.00	0.02	0.05
A3	0.10REF		
b	0.15	0.20	0.25
D	0.90	1.00	1.10
E	1.40	1.50	1.60
e	0.40	0.50	0.60
H	0.10REF		
L	0.30	0.35	0.40
L1	0.35	0.40	0.45

**Ordering information**

<b>Order code</b>	<b>Marking code</b>	<b>Package</b>	<b>Baseqty</b>	<b>Deliverymode</b>
SN74LVC1G07DBVR	C075	SOT23-5	3000	Tape and reel
SN74LVC1G07DCKR	CV5	SC70-5	3000	Tape and reel
SN74LVC1G07DRYR	CV	DFN6	5000	Tape and reel

## Disclaimer

EVVOSEMI ("EVVO") reserves the right to make corrections, enhancements, improvements, and other changes to its products and services at any time, and to discontinue any product or service without notice.

EVVO warrants the performance of its hardware products to the specifications applicable at the time of sale in accordance with its standard warranty. Testing and other quality control techniques are used as deemed necessary by EVVO to support this warranty. Except where mandated by government requirements, testing of all parameters of each product is not necessarily performed.

Customers should obtain and confirm the latest product information and specifications before final design, purchase, or use. EVVO makes no warranty, representation, or guarantee regarding the suitability of its products for any particular purpose, nor does EVVO assume any liability for application assistance or customer product design. EVVO does not warrant or accept any liability for products that are purchased or used for any unintended or unauthorized application.

EVVO products are not authorized for use as critical components in life support devices or systems without the express written approval of EVVOSEMI.

The EVVO logo and EVVOSEMI are trademarks of EVVOSEMI or its subsidiaries in relevant jurisdictions. EVVO reserves the right to make changes without further notice to any products herein.