

EVVOSEMI[®]

THINK CHANGE DO



ESD



TVS



MOS



LDO



Diode



Sensor



DC-DC

Product Specification

▶ Domestic	Part Number	SN74LVC1G17
▶ Overseas	Part Number	SN74LVC1G17
▶ Equivalent	Part Number	SN74LVC1G17

EV is the abbreviation of name EVVO

General Description

The SN74LVC1G17 is a single Non-inverting Schmitt Trigger Buffer in three tiny footprint packages.

Features

- Tiny SC70-5, SOT23-5 and DFN6-1.0mm*1.5mm Packages
- Source/Sink 24mA at 3.0V
- Chip Complexity: FETs = 20
- Designed for 1.65V to 5.5V V_{CC} Operation
- These Devices are Pb-Free, Halogen Free/BFR Free and are RoHS Compliant

Pin Configuration

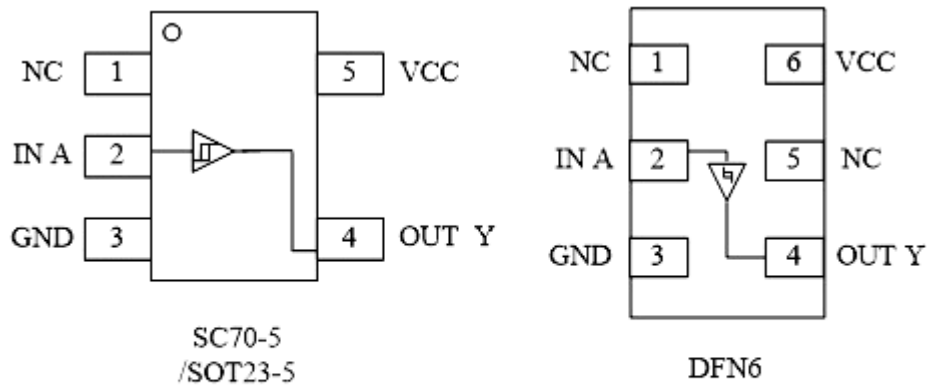

Figure1. Pinouts (Top View)

Pin Function

(SC70-5/ SOT23-5)

PIN	FUNCTION
1	NC
2	IN A
3	GND
4	VCC
5	OUT

DFN6

PIN	FUNCTION
1	NC
2	IN A
3	GND
4	VCC
5	NC
6	OUT

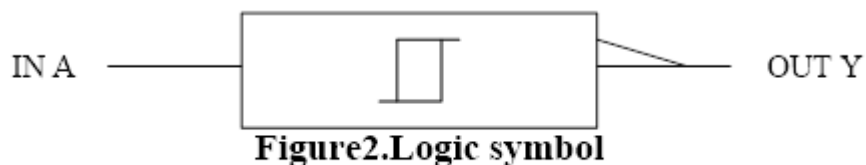
Block Diagram**Functional Description****Function Table**

Input	Output
A	Y
L	L
H	H

Absolute Maximum Ratings

Symbol	Parameter	Value	Unit
V _{CC}	DC Supply Voltage	-0.5 to 7.0	V
V _I	DC Input Voltage	-0.5 ≤ V _I ≤ +7.0	V
V _O	DC Output Voltage Output in Higher or Low State (Note 1)	-0.5 to V _{CC} + 0.5	V
I _{IK}	DC Input Diode Current V _I < GND	-50	mA
I _{OK}	DC Output Diode Current V _O < GND, V _O > V _{CC}	±50	mA
I _O	DC Output Sink Current	±50	mA
I _{CC}	DC Supply Current per Supply Pin	±100	mA
I _{GND}	DC Ground Current per Supply Pin	±100	mA
T _{STG}	Storage Temperature Range	-65 to 150	°C
T _L	Lead Temperature, 1 mm from Case for 10 Seconds	260	°C
T _J	Junction Temperature Under Bias	150	°C
θ _{JA}	Thermal Resistance	SC70-5 (Note 1)	435
		SOT23-5	300
		DFN6	450
P _D	Power Dissipation in Still Air at 85°C	SC70-5	150
		SOT23-5	200
		DFN6	130
MSL	Moisture Sensitivity	Level 1	
F _R	Flammability Rating Oxygen Index:28 to 34	UL94V-0@0.12in	
ESD	ESD Classification Human	Body Model (Note 2)	2000
		Machine Model (Note 3)	200
		Charged Device Model (Note4)	N/A
I _{Latchup}	Latchup Performance Above V _{CC} and Below GND at 125°C (Note 5)	±100	mA

Stresses exceeding Maximum Ratings may damage the device. Maximum Ratings are stress ratings only.

Functional operation above the Recommended Operating Conditions is not implied. Extended exposure to stresses above the Recommended Operating Conditions may affect device reliability.

1. Measured with minimum pad spacing on an FR4 board, using 10 mm-by-1 inch, 2-ounce copper trace with no air flow.

2. Tested to EIA/JESD22-A114-A, rated to EIA/JESD22-A114-B.

3. Tested to EIA/JESD22-A115-A, rated to EIA/JESD22-A115-A.

4. Tested to JESD22-C101-A.

5. Tested to EIA/JESD78.

Recommended Operating Conditions

Symbol	Parameter	Min	Max	Unit	
V _{CC}	DC Supply Voltage Operating	1.65	5.5	V	
	Date Retention	1.5	5.5		
V _{IN}	DC Input Voltage	0	5.5	V	
V _{OUT}	DC Output Voltage (High or Low State) (SOT-353/ SOT-23-5L/SOT-553 Packages)	0	5.5	V	
T _A	Operating Temperature Range	-55	125	°C	
t _r ,t _f	Input Rise and Fall Time	V _{CC} = 2.5 V ±0.2 V	0	20	ns/V
		V _{CC} = 3.0 V ±0.3 V	0	10	
		V _{CC} = 5.0 V ±0.5 V	0	5	

Electrical Characteristics

DC ELECTRICAL CHARACTERISTICS

Symbol	Parameter	Condition	V _{CC} (V)	T _A = 25 °C			-55°C ≤ T _A ≤ 125°C		Unit
				Min	Typ	Max	Min	Max	
V _{IH}	High-Level Input Voltage		1.65 to 1.95 2.3 to 5.5	0.75V _{CC} 0.7V _{CC}			0.75V _{CC} 0.7V _{CC}		V
V _{IL}	Low-Level Input Voltage		1.65 to 1.95 2.3 to 5.5			0.25V _{CC} 0.3V _{CC}		0.25V _{CC} 0.3V _{CC}	V
V _{OH}	High-Level Output Voltage V _{IN} = V _{IL}	I _{OH} = -100µA	1.65 to 5.5	V _{CC} - 0.1	V _{CC}		V _{CC} - 0.1		V
		I _{OH} = -3mA	1.65	1.29	1.52		1.29		
		I _{OH} = -8mA	2.3	1.9	2.1		1.9		
		I _{OH} = -12mA	2.7	2.2	2.4		2.2		
		I _{OH} = -16mA	3.0	2.4	2.7		2.4		
		I _{OH} = -24mA	3.0	2.3	2.5		2.3		
		I _{OH} = -32mA	4.5	3.8	4.0		3.8		
V _{OL}	Low-Level Output Voltage V _{IN} = V _{IH}	I _{OH} = 100µA	1.65 to 5.5		0.0	0.1		0.1	V
		I _{OL} = 3mA	1.65		0.08	0.24		0.24	
		I _{OL} = 8mA	2.3		0.20	0.3		0.3	
		I _{OL} = 12mA	2.7		0.22	0.4		0.4	
		I _{OL} = 16mA	3.0		0.28	0.4		0.4	
		I _{OL} = 24mA	3.0		0.38	0.55		0.55	
		I _{OL} = 32mA	4.5		0.42	0.55		0.55	
I _{IN}	Input Leakage Current	V _{IN} = 5.5V or GND	0 to 5.5		±0.1			±1.0	µA
I _{OFF}	Power Off Leakage Current	V _{IN} = 5.5V or V _{OUT} = 5.5V	0			1		10	µA
I _{CC}	Quiescent Supply Current	V _{IN} = 5.5V or GND	5.5					10	µA

Product parametric performance is indicated in the Electrical Characteristics for the listed test conditions, unless

otherwise noted. Product performance may not be indicated by the Electrical Characteristics if operated under different conditions.

AC ELECTRICAL CHARACTERISTICS $t_r=t_f= 2.5\text{ns}$; $C_L = 50\text{pF}$;
 $R_L = 500 \Omega$

Symbol	Parameter	Condition	V _{CC} (V)	TA = 25 °C			-55°C ≤TA≤125°C		Unit
				Min	Typ	Max	Min	Max	
t _{PLH} t _{PHL}	Propagation Delay (Figure3and4)	R _L = 1MΩ C _L = 15 pF	1.65	2.0	5.3	11.4	2.0	12.0	ns
			1.8	2.0	4.4	9.5	2.0	10.0	
		R _L = 1MΩ C _L = 15 pF	2.5±0.2	0.2	3.5	6.5	0.8	7.0	
		R _L = 1MΩ C _L = 15 pF	3.3±0.3	0.8	2.1	4.5	0.5	4.7	
		R _L = 500Ω C _L = 50 pF		1.2	2.9	5.5	1.5	5.2	
		R _L = 1MΩ C _L = 15 pF	5.0±0.5	0.5	1.8	3.9	0.5	4.1	
R _L = 500Ω C _L = 50 pF	0.8	2.4		4.3	0.8	4.5			

CAPACITIVE CHARACTERISTICS

Symbol	Parameter	Condition	Typical	Unit
C _{IN}	Input Capacitance	V _{CC} = 5.5 V, V _I = 0 V or V _{CC}	>2.5	pF
C _{PD}	Power Dissipation Capacitance (Note 6)	10 MHz, V _{CC} = 3.3 V, V _I = 0 V or V _{CC} 10 MHz, V _{CC} = 5.5 V, V _I = 0 V or V _{CC}	9 11	pF(Note 6)

6. C_{PD} is defined as the value of the internal equivalent capacitance which is calculated from the operating current consumption without load. Average operating current can be obtained by the equation:

$$I_{CC(OPR)}=C_{PD} \cdot V_{CC} \cdot f_{in}+I_{CC} \cdot C_{PD}$$

is used to determine the no-load dynamic power consumption;

$$P_D=C_{PD} \cdot V_{CC}^2 \cdot f_{in}+I_{CC} \cdot V_{CC} \cdot Fig.$$

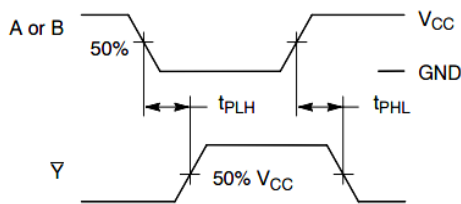
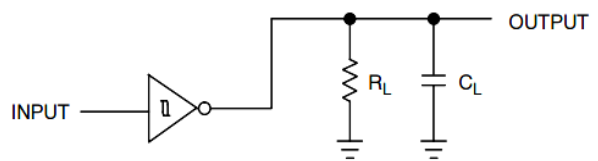

Figure 3. Switching Waveform



A 1-MHz square input wave is recommended for propagation delay tests.

Figure 4. Test Circuit

Package Dimension

SC70-5

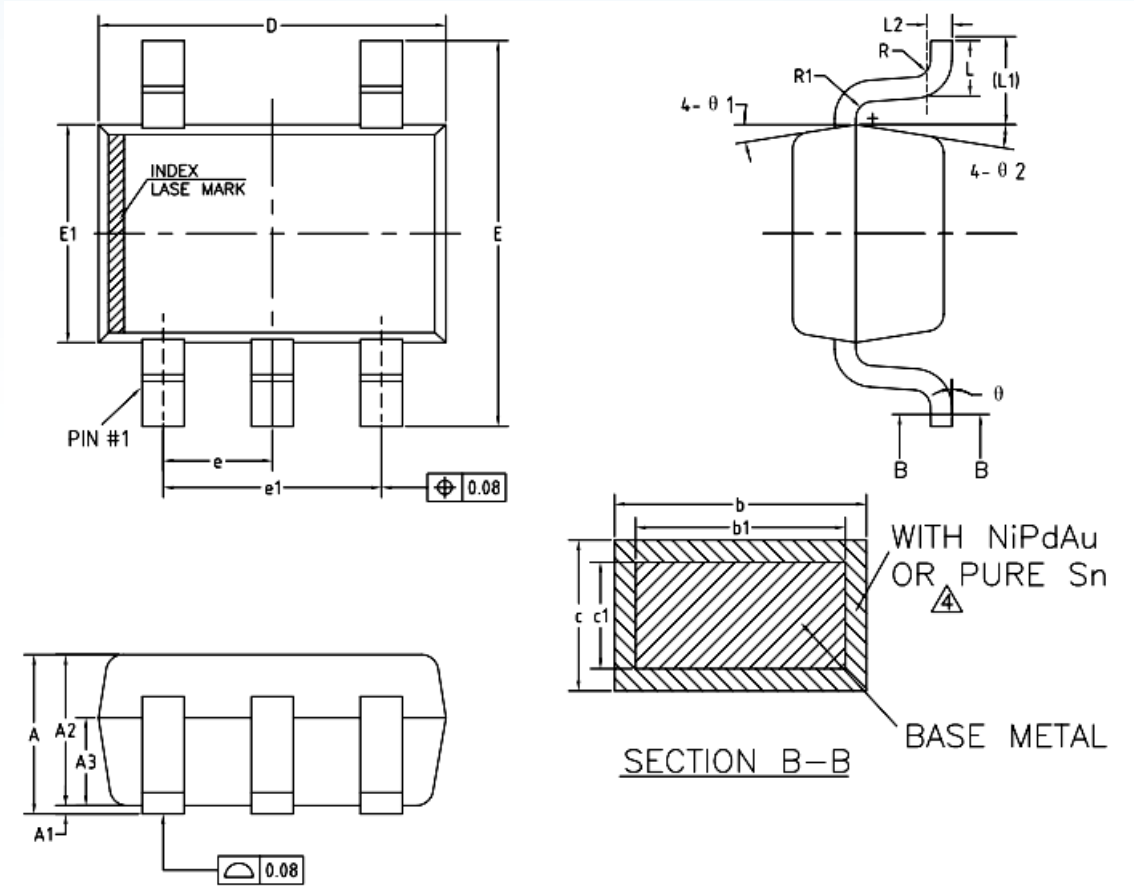

COMMON DIMENSIONS
(UNITS OF MEASURE=MILLIMETER)

SYMBOL	MIN	NOM	MAX
A	0.85	—	1.05
A1	0	—	0.10
A2	0.80	0.90	1.00
A3	0.47	0.52	0.57
b	NiPd Au 0.22	—	0.29
	PURE Sn 0.23	—	0.33
b1	0.22	0.25	0.28
c	NiPd Au 0.115	—	0.15
	PURE Sn 0.12	—	0.18
c1	0.115	0.13	0.14
D	2.02	2.07	2.12
E	2.20	2.30	2.40
E1	1.25	1.30	1.35
e	0.60	0.65	0.70
e1	1.20	1.30	1.40
L	0.28	0.33	0.38
L1	0.50REF		
L2	0.15BSC		
R	0.10	—	—
R1	0.10	—	0.25
θ	0°	—	8°
θ 1	6°	9°	12°
θ 2	6°	9°	12°

SOT23-5

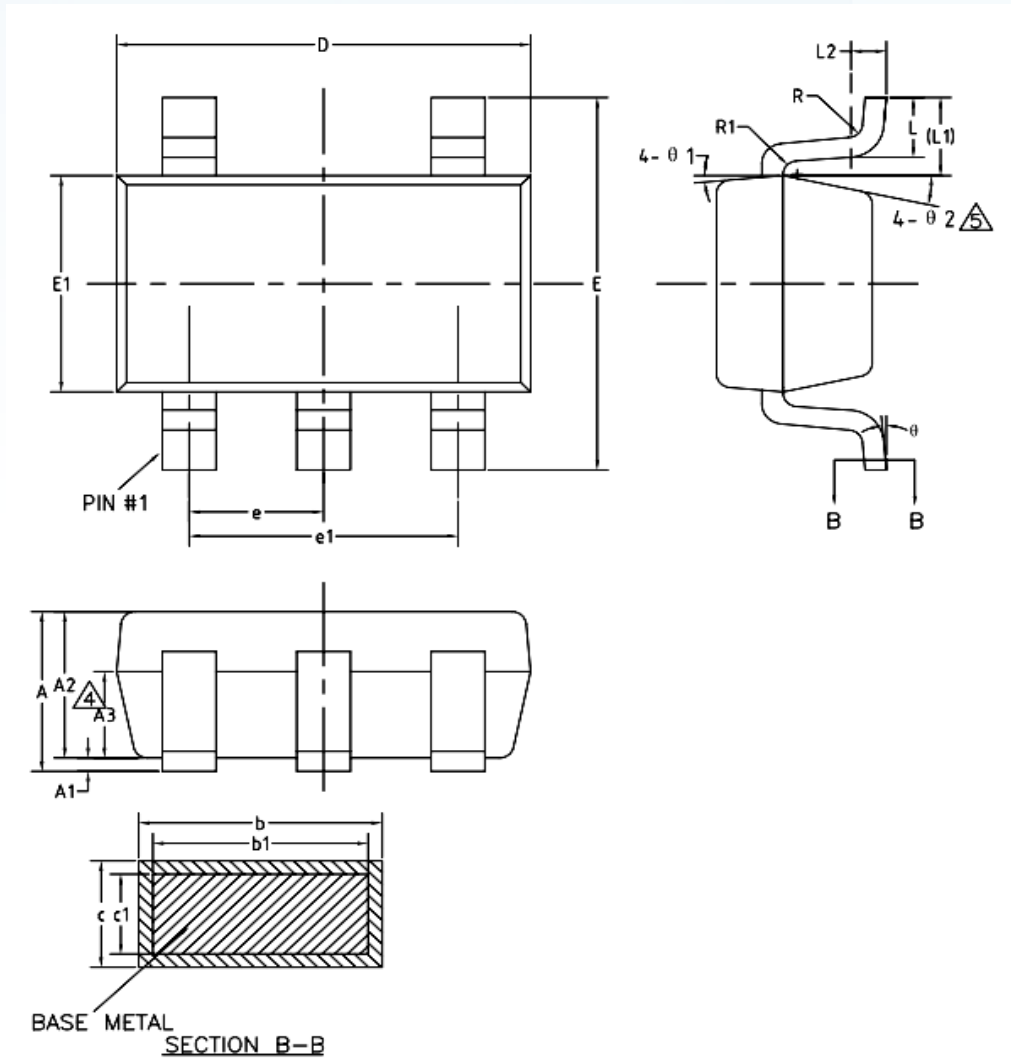

COMMON DIMENSIONS
(UNITS OF MEASURE=MILLIMETER)

SYMBOL	MIN	NOM	MAX
A	—	—	1.25
A1	0	—	0.15
A2	1.00	1.10	1.20
A3	0.60	0.65	0.70
b	0.36	—	0.50
b1	0.36	0.38	0.45
c	0.14	—	0.20
c1	0.14	0.15	0.16
D	2.826	2.926	3.026
E	2.60	2.80	3.00
E1	1.526	1.626	1.726
e	0.90	0.95	1.00
e1	1.80	1.90	2.00
L	0.35	0.45	0.60
L1	0.59REF		
L2	0.25BSC		
R	0.10	—	—
R1	0.10	—	0.25
θ	0°	—	8°
$\theta 1$	3°	5°	7°
$\theta 2$	6°	—	14°

DFN6

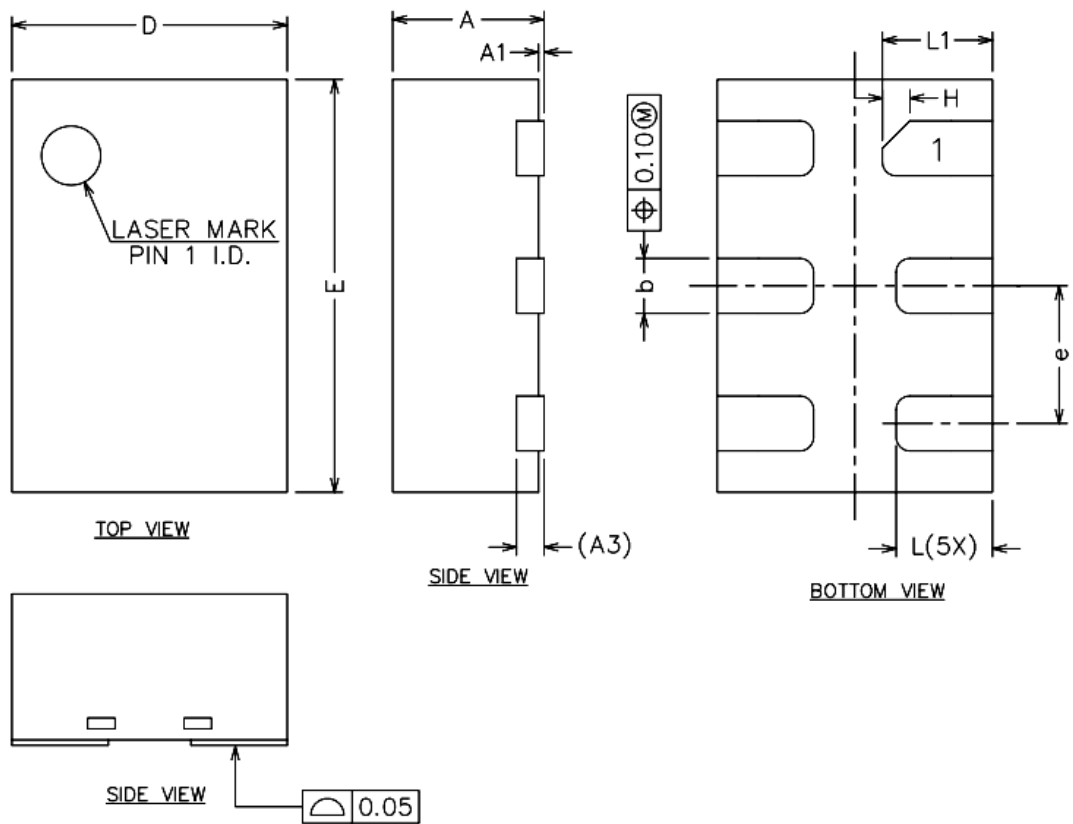

COMMON DIMENSIONS
(UNITS OF MEASURE=MILLIMETER)

SYMBOL	MIN	NOM	MAX
A	0.50	-	0.60
A1	0.00	0.02	0.05
A3	0.10REF		
b	0.15	0.20	0.25
D	0.90	1.00	1.10
E	1.40	1.50	1.60
e	0.40	0.50	0.60
H	0.10REF		
L	0.30	0.35	0.40
L1	0.35	0.40	0.45

Ordering information

Order code	Marking code	Package	Baseqty	Deliverymode
SN74LVC1G17DBVR	C17J	SOT23-5	3000	Tape and reel
SN74LVC1G17DCKR	C75	SC70-5	3000	Tape and reel
SN74LVC1G17DRYR	C7	DFN6	3000	Tape and reel

Disclaimer

EVVOSEMI ("EVVO") reserves the right to make corrections, enhancements, improvements, and other changes to its products and services at any time, and to discontinue any product or service without notice.

EVVO warrants the performance of its hardware products to the specifications applicable at the time of sale in accordance with its standard warranty. Testing and other quality control techniques are used as deemed necessary by EVVO to support this warranty. Except where mandated by government requirements, testing of all parameters of each product is not necessarily performed.

Customers should obtain and confirm the latest product information and specifications before final design, purchase, or use. EVVO makes no warranty, representation, or guarantee regarding the suitability of its products for any particular purpose, nor does EVVO assume any liability for application assistance or customer product design. EVVO does not warrant or accept any liability for products that are purchased or used for any unintended or unauthorized application.

EVVO products are not authorized for use as critical components in life support devices or systems without the express written approval of EVVOSEMI.

The EVVO logo and EVVOSEMI are trademarks of EVVOSEMI or its subsidiaries in relevant jurisdictions. EVVO reserves the right to make changes without further notice to any products herein.