

EVVOSEMI[®]

THINK CHANGE DO



ESD



TVS



MOS

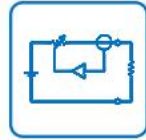

LDO

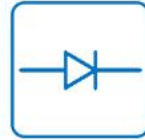

Diode

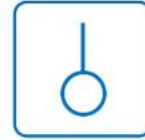

Sensor



DC-DC

Product Specification

▶ Domestic	Part Number	5KP Series
▶ Overseas	Part Number	5KP Series
▶ Equivalent	Part Number	5KP Series

EV is the abbreviation of name EVVO

Reverse Voltage: 5.0 to 440 V
Peak Pulse Power: 5000 W

Axial Lead Transient Voltage Suppressors

Features

- Glass passivated chip
- 5000 W peak pulse power capability with a 10/1000 μ s waveform, repetitive rate (duty cycle):0.01 %
- Low leakage
- Uni and Bidirectional unit
- Excellent clamping capability
- Very fast response time
- RoHS compliant

Mechanical Data

- Case: Molded plastic
- Epoxy: UL 94V-0 rate flame retardant
- Lead: Solderable per MIL-STD-202, method 208 guranteed
- Polarity: Color band denotes cathode end except Bipolar
- Mounting position: Any

R-6/P600

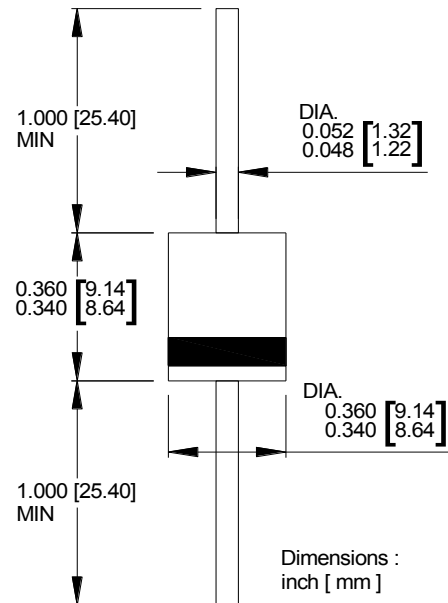

Maximum Ratings($T_A=25^{\circ}\text{C}$ unless otherwise noted)

Parameter	Symbol	Value	Unit
Peak power dissipation with a 10/1000 μ s waveform ⁽¹⁾	P_{PP}	5000	W
Peak pulse current wih a 10/1000 μ s waveform ⁽¹⁾	I_{PP}	See Next Table	A
Power dissipation on infinite heatsink at $T_L = 75^{\circ}\text{C}$	P_D	8.0	W
Peak forward surge current, 8.3 ms single half sine-wave unidirectional only ⁽²⁾	I_{FSM}	500	A
Maximum instantaneous forward voltage at 100 A for unidirectional only ⁽³⁾	V_F	3.5/5.0	V
Operating junction and storage temperature range	T_J, T_{STG}	- 55 to +150	$^{\circ}\text{C}$

Note:

(1)Non-repetitive current pulse per Fig.5 and derated above $T_A = 25^{\circ}\text{C}$ per Fig.1

(2)Measured on 8.3 ms single half sine-wave or equivalent square wave, duty cycle = 4 pulses per minute maximum

(3) $V_F < 3.5\text{V}$ for devices of $V_{BR} < 200\text{V}$ and $V_F < 5.0\text{V}$ for devices of $V_{BR} > 201\text{V}$

Ratings and Characteristics Curves ($T_A=25^{\circ}\text{C}$ unless otherwise noted)

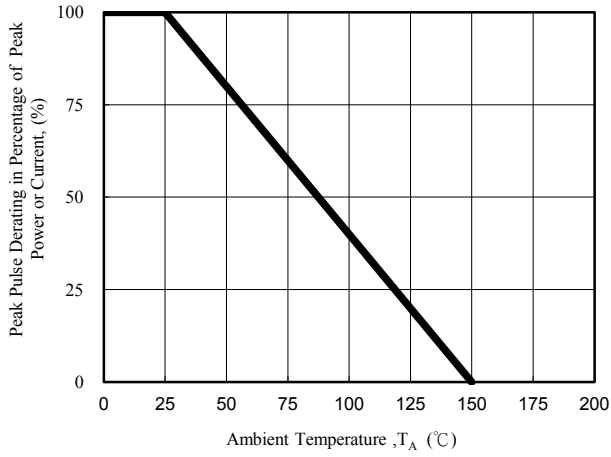

Fig. 1 - Pulse Derating Curve

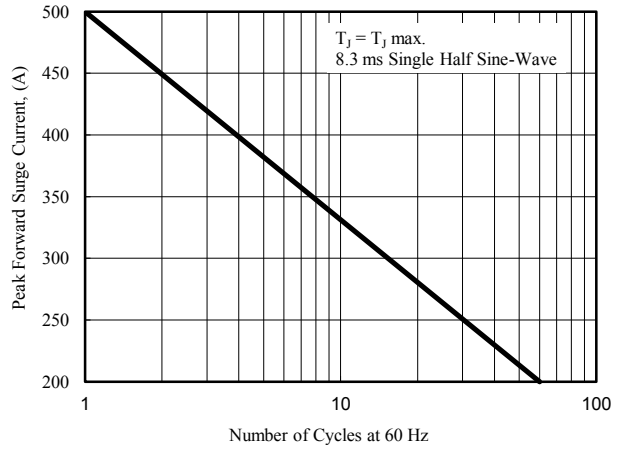

Fig. 2 - Maximum Non-Repetitive Surge Current

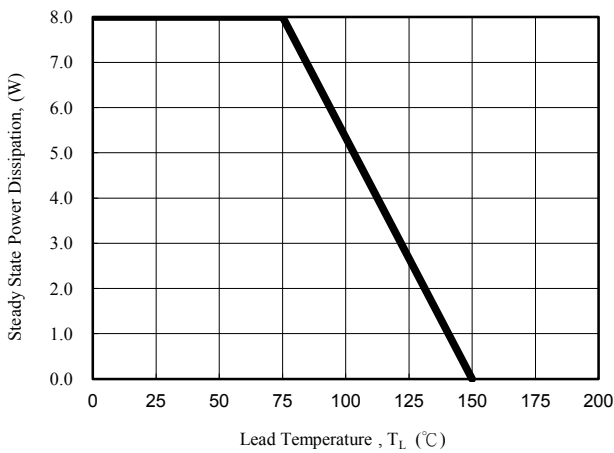

Fig. 3 - Steady State Power Derating Curve

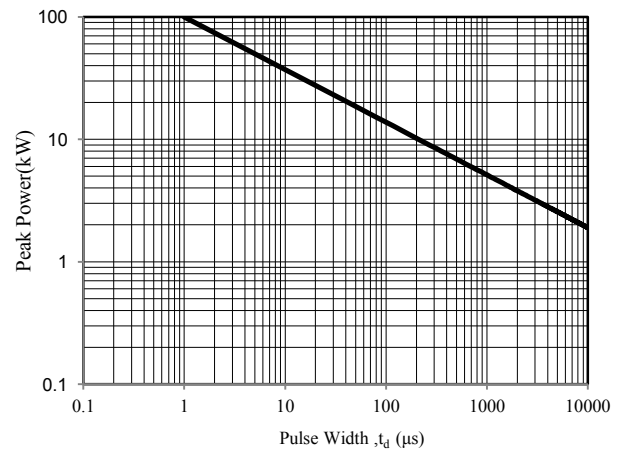

Fig. 4 - Peak Pulse Power Rating Curve

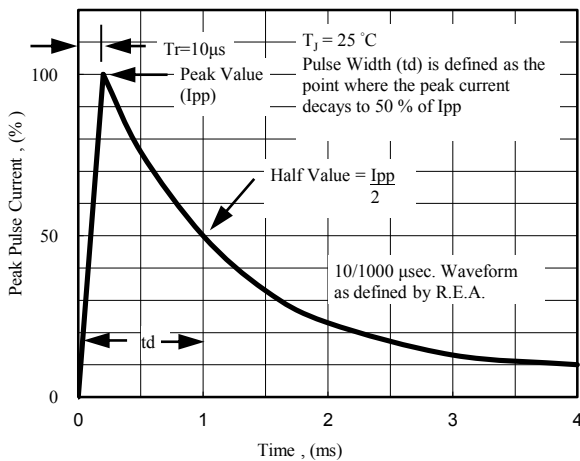

Fig. 5 - Pulse Waveform

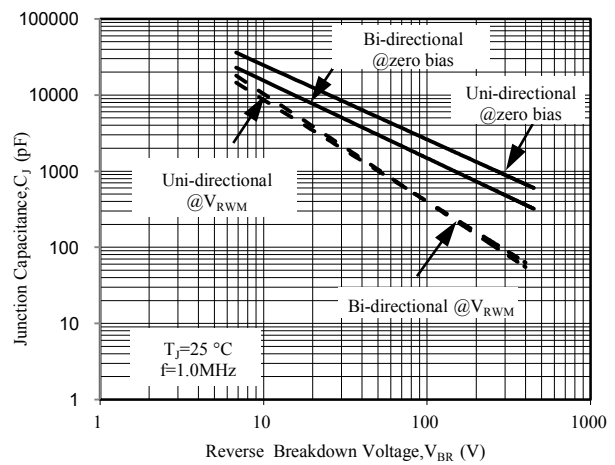

Fig. 6 - Typical Junction Capacitance

Electrical Characteristics($T_A=25^{\circ}\text{C}$ unless otherwise noted)

Part Number (Uni)	Part Number (Bi)	Breakdown Voltage V_{BR} @ I_T			Maximum Reverse Leakage I_R @ V_{RWM} (μA)	Working Peak Reverse Voltage V_{RWM} (V)	Maximum Reverse Surge Current I_{PP} (A)	Maximum Clamping Voltage V_C @ I_{PP} (V)
		Min (V)	Max (V)	I_T (mA)				
5KP5.0A	5KP5.0CA	6.40	7.00	50	5000	5	543.48	9.2
5KP6.0A	5KP6.0CA	6.67	7.37	50	5000	6	485.44	10.3
5KP6.5A	5KP6.5CA	7.22	7.98	50	2000	7	446.43	11.2
5KP7.0A	5KP7.0CA	7.78	8.60	50	1000	7	416.67	12.0
5KP7.5A	5KP7.5CA	8.33	9.21	5	250	8	387.60	12.9
5KP8.0A	5KP8.0CA	8.89	9.83	5	150	8	367.65	13.6
5KP8.5A	5KP8.5CA	9.44	10.4	5	50	9	347.22	14.4
5KP9.0A	5KP9.0CA	10.00	11.1	5	20	9	324.68	15.4
5KP10A	5KP10CA	11.10	12.3	5	15	10	294.12	17.0
5KP11A	5KP11CA	12.20	13.5	5	2	11	274.73	18.2
5KP12A	5KP12CA	13.30	14.7	5	2	12	251.26	19.9
5KP13A	5KP13CA	14.40	15.9	5	2	13	232.56	21.5
5KP14A	5KP14CA	15.60	17.2	5	2	14	215.52	23.2
5KP15A	5KP15CA	16.70	18.5	5	2	15	204.92	24.4
5KP16A	5KP16CA	17.80	19.7	5	2	16	192.31	26.0
5KP17A	5KP17CA	18.90	20.9	5	2	17	181.16	27.6
5KP18A	5KP18CA	20.00	22.1	5	2	18	171.23	29.2
5KP19A	5KP19CA	21.10	23.3	5	2	19	162.44	30.8
5KP20A	5KP20CA	22.20	24.5	5	2	20	154.32	32.4
5KP22A	5KP22CA	24.40	26.9	5	2	22	140.85	35.5
5KP24A	5KP24CA	26.70	29.5	5	2	24	128.53	38.9
5KP26A	5KP26CA	28.90	31.9	5	2	26	118.76	42.1
5KP28A	5KP28CA	31.10	34.4	5	2	28	110.13	45.4
5KP30A	5KP30CA	33.30	36.8	5	2	30	103.31	48.4
5KP33A	5KP33CA	36.70	40.6	5	2	33	93.81	53.3
5KP36A	5KP36CA	40.00	44.2	5	2	36	86.06	58.1
5KP40A	5KP40CA	44.40	49.1	5	2	40	77.52	64.5
5KP43A	5KP43CA	47.80	52.8	5	2	43	72.05	69.4
5KP45A	5KP45CA	50.00	55.3	5	2	45	68.78	72.7
5KP48A	5KP48CA	53.30	58.9	5	2	48	64.60	77.4
5KP51A	5KP51CA	56.70	62.7	5	2	51	60.68	82.4
5KP54A	5KP54CA	60.00	66.3	5	2	54	57.41	87.1
5KP58A	5KP58CA	64.40	71.2	5	2	58	53.42	93.6
5KP60A	5KP60CA	66.70	73.7	5	2	60	51.65	96.8
5KP64A	5KP64CA	71.10	78.6	5	2	64	48.54	103.0
5KP70A	5KP70CA	77.80	86.0	5	2	70	44.25	113.0
5KP75A	5KP75CA	83.30	92.1	5	2	75	41.32	121.0
5KP78A	5KP78CA	86.70	95.8	5	2	78	39.68	126.0
5KP80A	5KP80CA	88.80	97.6	5	2	80	38.58	129.6
5KP85A	5KP85CA	94.40	104.0	5	2	85	36.50	137.0
5KP90A	5KP90CA	100.00	111.0	5	2	90	34.25	146.0
5KP100A	5KP100CA	111.00	123.0	5	2	100	30.86	162.0
5KP110A	5KP110CA	122.00	135.0	5	2	110	28.25	177.0
5KP120A	5KP120CA	133.00	147.0	5	2	120	25.91	193.0
5KP130A	5KP130CA	144.00	159.0	5	2	130	23.92	209.0
5KP140A	5KP140CA	155.00	171.0	5	2	140	22.05	226.8
5KP150A	5KP150CA	167.00	185.0	5	2	150	20.58	243.0

Electrical Characteristics($T_A=25^{\circ}\text{C}$ unless otherwise noted)

Part Number (Uni)	Part Number (Bi)	Breakdown Voltage V_{BR} @ I_T			Maximum Reverse Leakage I_R @ V_{RWM} (μA)	Working Peak Reverse Voltage V_{RWM} (V)	Maximum Reverse Surge Current I_{PP} (A)	Maximum Clamping Voltage V_C @ I_{PP} (V)
		Min (V)	Max (V)	I_T (mA)				
5KP160A	5KP160CA	178.00	197.0	5	2	160	19.31	259.0
5KP170A	5KP170CA	189.00	209.0	5	2	170	18.18	275.0
5KP180A	5KP180CA	200.00	220.0	5	2	180	17.15	291.6
5KP190A	5KP190CA	211.00	232.0	5	2	190	16.24	307.8
5KP200A	5KP200CA	224.00	247.0	5	2	200	15.43	324.0
5KP210A	5KP210CA	233.00	258.0	5	2	210	14.31	349.5
5KP220A	5KP220CA	246.00	272.0	5	2	220	14.04	356.0
5KP250A	5KP250CA	279.00	309.0	5	2	250	12.35	405.0
5KP300A	5KP300CA	335.00	371.0	5	2	300	10.29	486.0
5KP350A	5KP350CA	391.00	432.0	5	2	350	8.82	567.0
5KP400A	5KP400CA	447.00	494.0	5	2	400	7.72	648.0
5KP440A	5KP440CA	492.00	543.0	5	2	440	7.01	713.0

Note:

1. Suffix 'A' denotes 5% tolerance device.
2. Add suffix 'C' or 'CA' after part number to specify Bi-directional devices
3. For Bi-Directional devices having V_R of 10 volts and under, the I_R limit is double

Disclaimer

EVVOSEMI ("EVVO") reserves the right to make corrections, enhancements, improvements, and other changes to its products and services at any time, and to discontinue any product or service without notice.

EVVO warrants the performance of its hardware products to the specifications applicable at the time of sale in accordance with its standard warranty. Testing and other quality control techniques are used as deemed necessary by EVVO to support this warranty. Except where mandated by government requirements, testing of all parameters of each product is not necessarily performed.

Customers should obtain and confirm the latest product information and specifications before final design, purchase, or use. EVVO makes no warranty, representation, or guarantee regarding the suitability of its products for any particular purpose, nor does EVVO assume any liability for application assistance or customer product design. EVVO does not warrant or accept any liability for products that are purchased or used for any unintended or unauthorized application.

EVVO products are not authorized for use as critical components in life support devices or systems without the express written approval of EVVOSEMI.

The EVVO logo and EVVOSEMI are trademarks of EVVOSEMI or its subsidiaries in relevant jurisdictions. EVVO reserves the right to make changes without further notice to any products herein.